

BREEDING CLIFF-NESTING BIRDS AT MINING SITES: MANAGEMENT RECOMMENDATIONS

Zoë Rohrer Rodríguez

Ph. D. Thesis 2019

Ph. D. Program in Ecology, Conservation
and Restoration of Ecosystems



Universidad de Alcalá

Recommended citation:

Rohrer Z. 2019. Breeding cliff-nesting birds at mining sites: Management recommendations. PhD Thesis. Universidad de Alcalá. Alcalá de Henares, España.

Background:

This document was developed through a partnership between LafargeHolcim Spain, the FIRE Foundation (Fundación Internacional para la Restauración de Ecosistemas) and the University of Alcalá, which began in 2016. Through this partnership, the three organizations work together to promote scientific and technological knowledge in the field of restoration ecology in mining sites, and in particular, in an innovative line of research to promote cliff-nesting birds in mining sites, both during the active life of the sites and the restoration phases.

Photographs:

Aiwok, CC BY-SA 3.0 (Chap. IV cover), Antonio Ojea (Cover page), Francisco Rosa García (Chap. VI cover), Hans Groen, Flicker Commons (Chap. V cover), Manuel Andrés Moreno (Acknowledgements cover), Navila Monteagudo (Abstract, Chaps. I, III and VII covers) and Ximo Galarza (Chap. II cover),

Photographic Appendix:

Navila Monteagudo, Javier Garrido Ajenjo, Zoë Rohrer Rodríguez, Manuel Andrés Moreno, Salvador Rebollo, Juan Franco, Carlos Rodríguez.

Design, illustrations and layout:

María Ley Oliver





BREEDING CLIFF-NESTING BIRDS AT MINING SITES: MANAGEMENT RECOMMENDATIONS

Ph.D. Thesis

Alcalá de Henares, May 2019

Ph.D. Thesis submitted by Zoë Rohrer Rodríguez for the degree of Doctor of Philosophy
Ph.D. Program in Ecology, Conservation and Restoration of Ecosystems (D413)
by the University of Alcalá

Supervisor:

Dr. Salvador Rebollo de la Torre

Department of Life Sciences
Universidad de Alcalá

D. SALVADOR REBOLLO DE LA TORRE, Profesor titular del Departamento de Ciencias de la Vida de la Universidad de Alcalá y tutor de esta Tesis Doctoral,

HACE CONSTAR:

Que el trabajo descrito en la presente memoria, titulado “**Breeding cliff-nesting birds at mining sites: Management recommendations**”, ha sido realizado por D/D^a Zoë Rohrer Rodríguez bajo su tutorización en el Departamento de Ciencias de la Vida de la Universidad de Alcalá, dentro del Programa de Doctorado “Ecología, Conservación y Restauración de Ecosistemas” (D413), reuniendo todos los requisitos necesarios para su aprobación como Tesis Doctoral.

Para que así conste y surta los efectos oportunos, se firma el presente informe en Alcalá de Henares a 17 de Mayo de 2019.

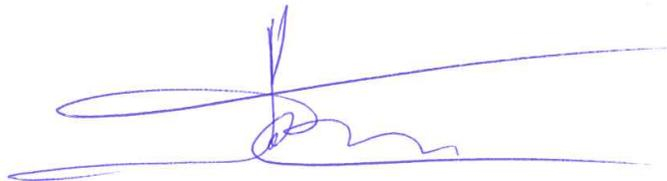

Fdo.: Salvador Rebollo de la Torre

D. MIGUEL ÁNGEL DE ZAVALA GIRONÉS, Coordinador de la Comisión Académica del Programa de Doctorado en “Ecología. Conservación y Restauración de Ecosistemas” (D413)

INFORMA que la Tesis Doctoral titulada “**Breeding cliff-nesting birds at mining sites: Management recommendations**”, presentada por D/D^a Zoë Rohrer Rodríguez bajo la dirección del / de la Dr/a. Salvador Rebollo de la Torre, reúne los requisitos científicos de originalidad y rigor metodológicos para ser defendida ante un tribunal. Esta Comisión ha tenido también en cuenta la evaluación positiva anual del doctorando, habiendo obtenido las correspondientes competencias establecidas en el Programa.

Para que así conste y surta los efectos oportunos, se firma el presente informe en Alcalá de Henares a 27 de Mayo de 2019.



Fdo.: Miguel Ángel de Zavala Gironés

CONTENT

Abstract / Resumen	1
Chapter I: General introduction	9
Chapter II: Description of cliff-nesting bird communities in mining sites in central and East Spain	29
Chapter III: Eagle Owl presence and diet at mining sites: Implications for restoration and management for cliff-nesting birds	43
Chapter IV: Restoration and management for cliff-nesting birds in Mediterranean mining sites: The Sand Martin case study	61
Chapter V: Bird services applicable to mining restoration: The Sand Martin (<i>Riparia riparia</i>) burrow construction case study	81
Chapter VI: General Discussion	99
Chapter VII: Conclusions	117
Acknowledgments	123
Supporting Information Chapter III	127
Supporting Information Chapter IV	133
Supporting Information Chapter V	153
Photographic Appendix	161

A mi madre.





ABSTRACT / RESUMEN

Abstract

To build infrastructures, we rely on the construction sector, which produces aggregates and cement through mining activity. The reconciliation of the extractive activity and conservation of natural values is a crucial issue. Currently, our capacity to return ecosystems affected by mining activity to their original situation is limited. An alternative to restoration is the creation of ecosystems for fauna of conservation concern. Cliff-nesting birds (birds that rely primarily on rocky or sandy walls to breed) colonize human-created environments such as mining sites (quarries and aggregate pits from the cement and aggregate sector). However, mining restoration often fails to consider the cliff-nesting fauna that may have colonized these areas. Furthermore, previous work has failed to address how important these man-made habitats are for the conservation of cliff-nesting birds, and how to manage their presence during the active phases of the mining sites. The aim of this PhD Thesis is to study the cliff-nesting bird community at mining sites, and to give management recommendations to enhance biodiversity by improving breeding habitats for cliff-nesting bird species in Mediterranean areas of Spain. We expect mining sites to have the potential of accommodating a varied community of cliff-nesting birds. We studied three aspects to manage these communities: 1) the potential risk of generating trap habitats by excess of predation; 2) the process of breeding habitat selection and habitat preferences of cliff-nesting birds at different scales; and 3) the ecological services of cliff-nesting birds that could be applied to restoration. To do this, we carried out a large scale survey in 2016 and 2017, in 29 mining sites during the breeding season, to study the abundance, richness and diversity of the cliff-nesting communities. The mining sites were representative of the environmental diversity of the study area. Then, we selected two model species. We studied the Eagle Owl's (*Bubo bubo*) presence and diet in mining sites and outlined restoration and management considerations for cliff-nesting birds to avoid excess predation pressure. We selected the Sand Martin (*Riparia riparia*) to analyze the ecology and habitat selection of cliff-nesting species in mining sites, and to establish measures to reconcile mining activity with their breeding populations. We also studied the provision of engineer ecosystem services of birds applicable to restoration actions, as a way of improving the local biodiversity of cliff-nesting birds, by studying the Sand Martin's burrowing activity at mining sites. Our results indicate that mining sites have a varied community of cliff-nesting birds and that for some species, these sites could be relevant as breeding habitats. We determined that the Eagle Owl is a specialist predator in the mining sites, with rabbits (*Oryctolagus cuniculus*) as its main prey, and that their frequent presence in these sites does not generate a risk of excess of predation of the cliff-nesting community. We observed that Sand Martins showed habitat preferences at the different studied scales, and that this information could be used to design management recommendations and restoration actions for this species. Finally, we observed that the burrowing activity of the Sand Martin generated holes that were colonized by secondary user birds and the Rock Sparrow (*Petronia petronia*) was the most abundant species. With this work, we aimed to explore alternatives to conventional restoration actions, to improve vulnerable biodiversity and to reconcile fauna with mining activity. Our study supports incorporating actions to promote cliffs, together with managing the mining sites to form a heterogeneous mosaic of habitats that satisfy the requirements of the cliff-nesting species (roosting, feeding, etc.). Finally, the study of these complementary habitats inside and outside the mining sites should be pursued in future lines of research, to improve the management and conservation of cliff-nesting species in mining sites.

Resumen

Para construir infraestructuras, dependemos del sector de la construcción, que produce áridos y cemento a través de la minería. La conciliación de la actividad extractiva y la conservación del medio ambiente es crucial. Actualmente, nuestra capacidad de retornar ecosistemas afectados por actividades extractivas a su situación original es limitada. Una alternativa a la restauración es la creación de ecosistemas para fauna de interés de conservación. Las aves rupícolas (aves que dependen principalmente de paredes rocosas o arenosas para reproducirse) colonizan ambientes antrópicos, como los espacios mineros (canteras y graveras de los sectores del cemento y los áridos). Sin embargo, la restauración minera a menudo ignora la avifauna rupícola que coloniza estos espacios. Además, estudios anteriores no han abordado la importancia de estos hábitats antrópicos para la conservación de las aves rupícolas y cómo gestionar su presencia en espacios mineros activos. El objetivo de esta Tesis Doctoral es estudiar la comunidad de aves rupícolas en espacios mineros y dar recomendaciones de gestión para promover biodiversidad mediante la mejora de los hábitats de reproducción de las aves rupícolas, en zonas mediterráneas de España. Esperamos que los espacios mineros tengan el potencial de alojar a una variada comunidad de aves rupícolas. Estudiamos tres aspectos: 1) el riesgo potencial de generar hábitats trampa por exceso de depredación; 2) el proceso de selección del hábitat de reproducción y las preferencias de hábitat de las aves rupícolas a diferentes escalas; y 3) los servicios ecológicos de las aves rupícolas aplicables a la restauración. Para ello, llevamos a cabo un monitoreo a gran escala en 2016 y 2017 en 29 espacios mineros, durante la temporada de reproducción, para estudiar la abundancia, riqueza y diversidad de las comunidades de avifauna rupícola. Los espacios mineros fueron representativos de la diversidad ambiental del área de estudio. Posteriormente, seleccionamos dos especies modelo. Estudiamos la presencia y la dieta del Búho real (*Bubo bubo*) en espacios mineros y esbozamos medidas de restauración y gestión de aves rupícolas para evitar una presión excesiva de depredación. Seleccionamos al Avión zapador (*Riparia riparia*) para analizar la ecología y selección del hábitat de reproducción de especies rupícolas en espacios mineros, y para establecer medidas para conciliar la actividad minera con sus poblaciones reproductoras. A través del estudio de la actividad de excavación del Avión zapador en espacios mineros, estudiamos los servicios de la avifauna con actividad ingeniera aplicables a la restauración como una forma de mejorar la biodiversidad local de aves rupícolas. Nuestros resultados indican que los espacios mineros acogen una diversa comunidad de aves rupícolas y que, para algunas especies, estos espacios podrían ser relevantes hábitats de reproducción. Determinamos que en los espacios mineros el Búho real es un depredador especializado, siendo los conejos (*Oryctolagus cuniculus*) su presa principal, y que la presencia frecuente del Búho real en estos espacios no genera un riesgo de exceso de depredación de la comunidad de aves rupícolas. Observamos que el Avión zapador mostró preferencias de hábitat en las diferentes escalas estudiadas, y utilizamos esta información para diseñar recomendaciones de gestión y acciones de restauración para esta especie. Finalmente, observamos que las madrigueras del Avión zapador fueron colonizadas por aves usuarias secundarias, y que el Gorrión chillón (*Petronia petronia*) fue la especie más abundante. Con este trabajo, buscábamos explorar alternativas a las acciones de restauración convencionales, mejorar biodiversidad vulnerable y conciliar la fauna con la actividad minera. Nuestro estudio apoya la incorporación de acciones para promover paredes verticales, junto con la gestión de los espacios mineros para formar un mosaico heterogéneo de hábitats que cumplan los requisitos de las especies rupícolas (lugares de descanso, alimentación, etc.). Finalmente, el estudio de estos hábitats complementarios dentro y fuera de los espacios mineros debe realizarse en futuras líneas de investigación, para mejorar la gestión y conservación de especies rupícolas en espacios mineros.

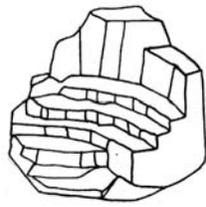



CHAPTER I

General introduction

CHAPTER I

General introduction

ORIGINAL SCIENTIFIC PUBLICATIONS

This PhD Thesis is based on four original research studies, which were carried out during the three-year period of the duration of the PhD Program (May 2016 until May 2019). One of them is presented as a descriptive chapter regarding the cliff nesting bird communities in mining sites and will be developed into an article after the defense of the PhD Thesis. The other three original research studies are presented as original research articles and are currently in review in indexed international academic journals from the Ecological Restoration and Ornithology fields. Collaborations are indicated in Table I.1.

- **Chapter II:** Rohrer Z, Rebollo S. Description of cliff-nesting bird communities in mining sites in central and East Spain (descriptive chapter)
- **Chapter III:** Rohrer Z, Rebollo S, Monteagudo N, Talabante C. Eagle Owl diet at mining sites: Implications for restoration and management for cliff-nesting birds. *Ibis* (original research article)
- **Chapter IV:** Rohrer Z, Rebollo S, Andivia E, Franco J, Rodríguez C. In review. Restoration and management for cliff-nesting birds in Mediterranean mining sites: The Sand Martin case study. *Restoration ecology* (second revision, original research article).
- **Chapter V:** Rohrer Z, Rebollo S, Andivia E, Rodríguez C, Franco J. In review. Bird services applicable to mining restoration: The Sand Martin (*Riparia riparia*) burrow construction case study. *Journal of Ornithology* (second revision, original research article).

Table I.1 Table of author contributions for each research chapter (Chapters II, III, IV, V). CR: Carlos Rodríguez, CT: Carlos Talabante, EA: Enrique Andivia, JF: Juan Franco, NM: Navila Monteagudo, SR: Salvador Rebollo, ZR: Zoë Rohrer.

	Chp. II	Chp. III	Chp. IV	Chp. V
Conception and design of the research	SR, ZR	SR, ZR	SR, ZR	SR, ZR
Data collection	ZR	ZR, NM, CT	ZR, JF, CR, SR	ZR, JF, CR, SR
Statistical Analysis		ZR	ZR, EA	ZR, EA
Edition of the manuscript	ZR, SR	ZR, SR	ZR, SR, EA	ZR, SR, EA
Revision of the manuscript	ZR, SR	ZR, SR, NM, CT	ZR, SR, EA	ZR, SR, EA

OTHER SCIENTIFIC PUBLICATIONS

Ruiz-Benito P, Andivia E, Archambeau J, Astigarraga J, Barrientos R, Cruz-Alonso V, Florencio M, Gómez D, Martínez-Baroja L, Quiles P, Rohrer Z, Santos AMC, Velado E, Villén-Pérez S, Morales-Castilla I (2018) Ventajas de la estadística bayesiana frente a la frecuentista: ¿Por qué nos resistimos a usarla? *Ecosistemas*, **27**(2):136-139

OTHER PUBLICATIONS

As well as scientific publications, Z. Rohrer has participated actively in contributing to disseminate this research in other forums.

Federación de Áridos (FdA) (2019) *Contribución del sector de los áridos a la recuperación de una especie amenazada El avión zapador*. Madrid, Spain

Mola I, Sopeña A, de Torre R (editores). (2018) *Guía Práctica de Restauración Ecológica*. Fundación Biodiversidad del Ministerio para la Transición Ecológica. Madrid. 77 pp. <https://ieeb.fundacion-biodiversidad.es/content/guia-practica-de-restauracion-ecologica> (accessed 16 May 2019)

Rohrer Z, Rebollo S, Gegúndez P, Monteagudo N, Garrido J (2016) *Oportunidades para la recreación de hábitats para la avifauna rupícola en espacios mineros*. Comunicación técnica. CONAMA 2016, Madrid, Spain <http://www.conama2016.conama.org/web/generico.php?idpaginas=&lang=es&menu=405&id=1366&op=view&tipo=C> (accessed 10 March 2018)

Rohrer Z, Rebollo S, Monteagudo N, Gegúndez P (2017) Mejora de hábitats para avifauna rupícola en espacios mineros: oportunidades para la recreación de hábitats. Pages: 131 – 142 In: Ros Magán G, Guerrero Ortega A, Pascual Vive F, Tejedor Martínez C, Ruiz Benito P, Taberner Magro V (eds) *Sextas Jornadas de Jóvenes Investigadores de la Universidad de Alcalá (Ciencias e Ingenierías)*. Universidad de Alcalá. Alcalá de Henares, Spain. I.S.B.N.: 978-84-16599-48-6

Rohrer Z, Rebollo S, Gegúndez P (2018) *Guía de buenas prácticas para el avión zapador en explotaciones de áridos*. LafargeHolcim, FIRE & UAH. Madrid, Spain. https://www.researchgate.net/publication/328430344_Guia_de_buenas_practicas_para_el_avion_zapador_en_explotaciones_de_aridos (accessed 10 May 2019)

Rohrer Z, Rebollo S, Gegúndez P, Rey Benayas JM, Pérez Suárez R, Rubio P (2018) Contribución del sector de los áridos a la conservación del avión zapador. *Revista Técnica CEMENTO HORMIGÓN*, **987**:18-21

Rohrer Z. 2019. Oportunidades para la mejora del hábitat de la avifauna rupícola en canteras. *Revista Técnica CEMENTO HORMIGÓN*, **990**:13-14

SEO Birdlife (2019) *Aves comunes en explotaciones mineras ibéricas*. Madrid, Spain.

FUNDING

This project was financed through a partnership between the International Foundation for the Restoration of Ecosystems (FIRE), LafargeHolcim Spain and the Life Sciences Department (Ecology Unit) and supported by the Forest Ecology and Restoration Group (FORECO) of the University of Alcalá (UAH) and the REMEDINAL network. E. Andivia was supported by a postdoctoral grant funded by the Universidad Complutense de Madrid (UCM). N. Monteagudo was supported by a predoctoral grant funded by the University of Alcalá (UAH).

ETHICAL STATEMENT

All applicable international, national, and/or institutional guidelines for the care and use of animals were followed. All procedures performed in studies involving animals were in accordance with the ethical standards of the Spanish Ministry of Agriculture, Environment and Food (MITECO) and the Dirección General del Medio Ambiente de la Consejería de Medio Ambiente, Administración Local y Ordenación del Territorio de la Comunidad de Madrid (REF:10/148281.9/17 with date 18/05/2017). Bird manipulation was done by an expert (Manolo Andrés Moreno) of SEO/Birdlife's and the Bird Migration Center and with authorization for Scientific Banding of the Spanish Ministry of Agriculture, Environment and Food (permit number nº 530339). We declare that this work fully complied with the current Spanish laws. LafargeHolcim Spain granted access to all of the studied mining sites, and all of the security requirements and procedures were complied with.

INTRODUCTION

I. Mining restoration

To build infrastructures, we rely on the industrial activity of the construction sector, which produces aggregates and cement through mining activity. Aggregates (sand, gravel, crushed rock, recycled and manufactured aggregates) are produced from natural sources extracted from quarries and from sand and aggregate extraction sites. Cement is a material formed from a processed mixture of limestone and clay, and it is produced in cement plants. To give visual examples, every new individual home typically requires up to 400 tons of aggregates, which is equivalent to the weight of 200 cars. Or a new sports stadium may require up to 300,000 tons of aggregates, which in surface would be enough to cover the area of Disney World three times (UEPG 2019). Due to this extraction of natural resources, mining causes strong impacts on geomorphology, hydrology, subsoil, soil and vegetation.

Restoration activities are one of the essential phases of a mining site's life cycle, which marks the end of an activity that can have been operating for decades. *Ecological restoration* is an activity that initiates or accelerates the recovery of an ecosystem that has been degraded, damaged, transformed or destroyed as a direct or indirect result of human activities (SER 2002). Its objectives are directed towards the restoration and conservation of key ecosystem processes. However, trying to restore to its original condition the organization and function of an ecosystem where mining activity has taken place, is a challenge that is often difficult to achieve in the short and medium term, and often it is simply impossible with the current scientific knowledge.

For this reason, there are other approaches to ecological restoration. Depending on the

state which was chosen as reference point and the applied techniques, different levels of restoration can be achieved. According to the Society for Ecological Restoration (SER 2004) (Figure 1.1), *rehabilitation* takes place when one or several selected components of the original ecosystem are repaired, often certain target species or processes. Second, *reclamation* (also called replacement or reallocation) conceptually means reclaiming areas/ecosystems to other uses, such as agricultural or recreation. Finally, *creation* (also known as fabrication) consists of the installation of a different kind of ecosystem from that which occurred historically. Creation can allow the restoration of some attributes of the former ecosystem and the provision of new ecosystem services, even to the point of increasing the ecological value of an area (Bradshaw 1996), in terms of e.g. abundance of species of conservation concern. Generally, when creating new ecosystems, landscape integration is pursued, both from an aesthetic and functional point of view, and attempts are made to imitate reference systems.

Creation is a common alternative approach to restorations in mining sites which are not always possible or viable. It is also an alternative to rehabilitations which often do not generate self-sufficient ecological systems, and therefore usually involve large economic costs in both the short and long term. Taking into account that mining usually lasts for decades at a given mining site, another advantage of creation of ecosystems for wildlife is that the ecosystems can be implemented both during the active phases of mining exploitation as well as during final restoration measures.

There are many examples of habitat creation in mining restoration projects, such as forest or wetland habitats (Cooke & Johnson 2002; Lamb et al. 2005; Bullock et al. 2011). However, creation or enhancement of cliff habitats for conservation

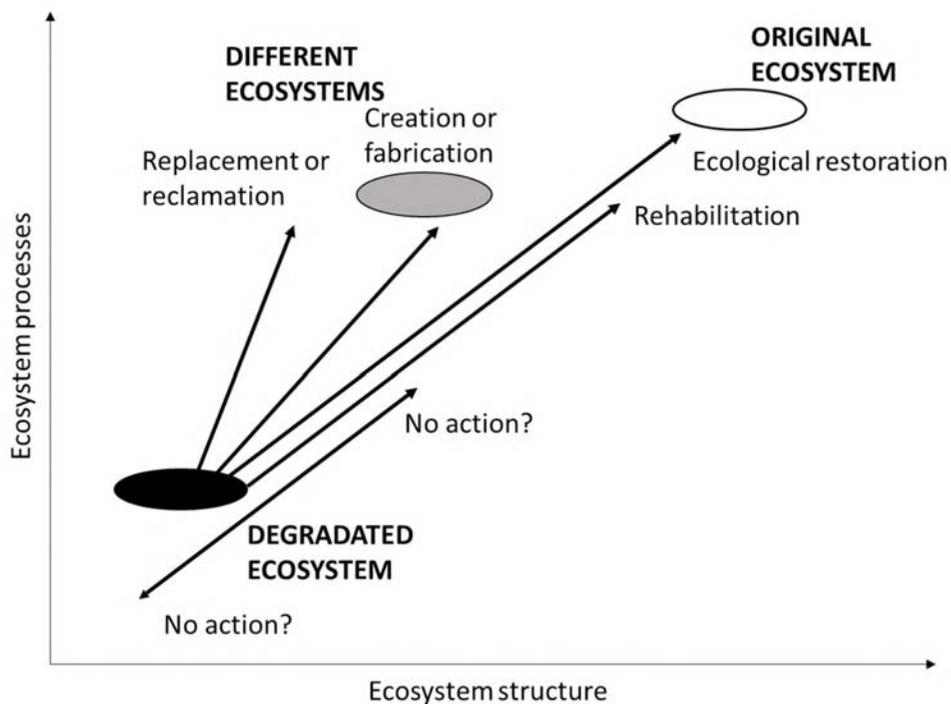

Figure 1.1 Relation between ecosystem structure (e.g. species diversity and complexity) and ecosystem function (e.g. biomass and nutrient content), illustrating different strategies to recover a degraded ecosystem. 1) *Ecological restoration* involves recovering what was there previously as completely as possible (the reference ecosystem is the original ecosystem); 2) *Rehabilitation* involves progressing towards this, but the two activities differ in their goals and strategies, as the rehabilitation emphasizes the reparation of one or several selected ecosystem components or processes, productivity and services. 3) *Reclamation* usually is returning the land to what, within the regional context, is considered to be a useful purpose, such as agriculture or recreation. 4) *Creation* can be an option when a site has undergone sufficient change to require the installation of a different kind of ecosystem from that which occurred historically. 5) *When no action* is made to restore what was present, the site may undergo normal succession or, if the site is liable to erosion or some other wasting process, to further degradation. Modified from Bradshaw (1984) and SER (2004).

purposes has been a line of action that has not been as explored, and mining restoration could offer an opportunity to increase the availability of locally scarce cliff habitats, as well as to reconcile mining activity with biodiversity conservation.

Why cliff-nesting birds?

Birds that typically breed in cliff habitats are known as cliff-nesting birds (Donázar et al. 1989, Brambilla et al. 2006) and some of the cliff-nesting species are protected (Madroño et

al. 2004). Many cliff-nesting birds have proven considerable ability to adapt to anthropogenic environments if these fulfill their ecological requirements (Ritchie et al. 1998; Marchesi et al. 2002). One of the most extensively colonized environments are mining sites like quarries and aggregate pits, where cliff habitats are created during mining activity, and which can accommodate a wide range of birds, from large raptors such as the Eagle Owl (*Bubo bubo*) to small passerines such as the Black Wheatear (*Oenanthe leucura*) (Brambilla et al. 2006;

Noguera et al. 2014; Soler 2014; Gahbauer et al. 2015; Burke 2017).

Cliffs are generally recognized as valuable habitats. However, the reproduction of fauna in highly anthropogenic habitats is frequently ignored or underestimated and to the best of our knowledge, there is little literature regarding the bird community that colonizes these man-made cliffs, including cliff-nesting birds. Reasons for this could be that a) scientists might eschew artificial habitats in favor of more natural ecosystems, b) that the substantial impacts of the mining industry make these habitats less attractive for scientists specialized in conservation biology and ecology, c) a lack of specialized studies because it is taken for granted that these environments are not acceptable as breeding sites, and d) the influence of legislation which was developed in a time when the conception of the natural environment was different and the technical knowledge on how to restore degraded habitats was less developed (Castillo et al. 2008).

Mining restoration practices normally involve eliminating the cliffs by shaping soft slopes, placing a substrate, and planting herbaceous covers (Noguera et al. 2014). Turning them into agricultural fields or landfill sites for domestic and industrial rubbish is also a very extended practice (Mborah et al. 2015). These actions normally do not consider the fauna that has colonized these mining sites, and can even be detrimental to cliff-nesting species and beneficial to more generalist species (Castillo et al. 2008; Noguera et al. 2014). Ignoring such natural assets both during the active and restoration phases could represent a lost opportunity for the conservation and expansion of cliff-nesting birds of conservation interest, and enhancement of local biodiversity.

Birds can colonize mining sites very quickly, even while mining sites are still active. Some cliff-nesting birds have increased the use of mining

sites as breeding habitats over the last decades, and some of them have relevant proportions of their populations in these anthropic sites, as has been described for some raptor species in some geographic locations (Zuberogoitia et al. 1994; Norriss 1995; Castillo et al. 2008). Natural populations of some species even seem to be becoming rare, like in the case of the Sand Martin (*Riparia riparia*) (SCV 1999; Heneberg 2007; Burke 2017). However, there is very little literature regarding management for fauna with the aim to reconcile mining activity with the presence of these protected species, and on how to develop restoration plans to promote and maintain their presence. The few references we are aware of regarding how to favor cliff-nesting birds, are only related to the creation of artificial nests for raptors and corvids (Boyce et al. 1980; Brambilla et al. 2010; Ostlyngen et al. 2011), there are very few examples of making shelves directly on the cliffs (Pagel 1989), and they are not usually performed in mining sites. There are not many examples for burrowing cliff-nesting birds either (Gulickx et al. 2007).

Therefore, there is a gap in knowledge on how to reconcile breeding cliff-nesting birds at mining sites with the industrial activity. For this, studying the species' composition of the cliff-nesting bird community colonizing mining sites and carrying out detailed studies about their habitat requirements, habitat preferences and functions could be helpful in designing effective conservation and restoration plans (Martínez et al. 2003). Furthermore, management guidelines for practitioners based on scientific knowledge are lacking for the cliff-nesting species.

Ecological traps

Opposed to revegetation, where the most frequent approaches in restoration consist of planting seeds or seedlings produced in nurseries, restoration techniques to recover

animal communities often include attracting individuals from wild populations, usually full-grown breeding individuals (Rebollo 2016). This means that wildlife recovery actions could have negative consequences for the surrounding populations (Hale & Swearer 2017), because the restored habitats could attract with preference the best individuals of a population to an area where their reproductive success will be negative, therefore creating a potential risk of generating trap habitats (Battin 2004). Trap habitats (or ecological traps) are low-quality habitats for reproduction and survival, which cannot sustain a population, and yet are preferred over other alternative high-quality habitats (Donovan & Thompson III 2001). Some authors have warned of the risk of creating trap habitats in restoration projects and pointed out that this option has been hardly explored in restoration studies (Hale & Swearer 2017).

Habitat enhancement actions for wildlife can also have negative demographic effects, such as density traps, *sensu* Rodenhouse et al. (1997). For example, if the actions increase the density of individuals, they could trigger dense-dependent negative effects. An example of this are nest boxes, which can increase the density of breeding pairs and increment rates of competition, predation, disease, etc. (Poysa & Poysa 2003; Mänd et al. 2009). The creation of trap habitats has also been demonstrated as a consequence of actions to enhance habitats for wildlife in locations where individuals will later be subjected to intense predation (Hawlena et al. 2010). Restored habitats could turn into a trap habitat if the individuals are attracted with preference to a place where the risk of predation is higher than in non-restored habitats, decreasing the fitness (ability to survive and produce successful offspring) of the colonizing populations. The individuals colonizing the restored habitat could then suffer increased predation that could in turn condition their

future viability.

The suitability of restoration actions for fauna, such as habitat creation, should not be evaluated solely on the success of the colonization of the restored environments, but also on the future viability of the installed populations (Hale & Swearer 2017). And in this regard, taking into account predation effect over populations in restored areas should be essential to evaluate whether restoration projects are successful.

In the case of cliff habitats in mining sites, raptors are cliff-nesting top predators that frequently breed in mining-generated cliffs (Zuberogoitia et al. 1994; Marchesi et al. 2002; Brambilla et al. 2006; Dalbeck & Heg 2006). Birds could be subjected to a strong attraction to nest in mining sites, and through habitat improvement or habitat creation actions, this effect could become even more far-reaching both for the raptors and the rest of the cliff-nesting species. It has been described that birds commonly experience traps caused by predation (Ekroos et al. 2012). This implies that successful habitat improvement actions directed at cliff-nesting species at mining sites could have the potential risk of creating ecological traps by excess predation by raptors. Trap habitats should be considered a potentially widespread concern in restoration actions involving wildlife.

Sand Martins as a study case

To study cliff-nesting species in depth, we selected the Sand Martin (*Riparia riparia*) as our case study. Sand Martins are burrowing cliff-nesting, colonial breeders. Currently, their populations are experiencing a long-term negative trend in several European countries, including Spain (BirdLife International 2016). Their natural nesting habitats are sandy banks of rivers, streams and lakes (Cramp 1988), but in recent decades they have been increasingly nesting in man-made structures (Etxezarreta 2010). They have been particularly nesting in

mining sites, to the point that natural colonies in some places in Europe are becoming rare (Heneberg 2005; SCV 2007; Burke 2017). This could be due to a combination of factors, but the alteration of river banks and their flow regimes, which makes the natural nesting habitat of Sand Martins scarce, and an increase in the past decades of the abundance of mining sites for aggregate production, could be favoring this phenomenon (Moffatt et al. 2005; Garcia 2009; Girvetz 2010; Wright et al. 2011).

Mining sites could be important breeding areas for the Sand Martin and therefore the management that is carried out in these places could be crucial for their populations, both in sites with mining activity and in restored sites. To be able to propose management recommendations in mining sites, we need to understand its habitat preferences in these areas. Habitat selection is a process in which the animal decides which habitats it uses at different spatial scales, ultimately seeking survival and reproductive success (Brambilla et al. 2006). As far as we can tell, very few studies address habitat selection of the Sand Martin in mining sites.

Once the habitat preferences of the Sand Martin in mining sites are known, guidelines for the promotion and management of this species can be developed, in such a way that Sand Martins are promoted in favorable sectors of the mining sites and their presence is avoided in industrially active areas during the breeding season. Some guidelines already exist in Switzerland (Bachmann et al. 2008) and Canada (Ontario Ministry of Natural Resources and Forestry 2017). However, guidelines adapted to the peculiarities of the species in Mediterranean contexts are lacking. Regional guidelines are important as the species can show variations, such as in the phenology of migration and reproduction, and habitat preferences.

Ecosystem services provided by cliff-nesting birds applied to restoration

Birds are possibly the group of terrestrial vertebrates with the most varied spectrum of ecological functions (Sekercioglu 2006). They can provide many ecosystem services, including trophic-related ones, like seed dispersion, pollination or nutrient cycling (Whelan et al. 2008). They can also supply beneficial non-trophic-related services, such as constructing potential refuge for fauna (Wenny et al. 2011). Therefore, the nest building activity of some birds generates burrows that can be colonized by many other secondary cavity-nesting species, who have no capacity to build holes, but need them for shelter or reproduction (Casas-Crivillé & Valera 2005).

The abundance of holes could limit the colonization of mining areas by secondary cliff-nesting birds, the same way it occurs for other secondary cavity-nesting species in non-mining environments (Cockle et al. 2010). In mining areas, cavities are generated mainly by mining activity, but also by abiotic (e.g. water erosion) and biotic agents (e.g. burrowing species). The primary cavity-nesting species (burrowing species) could increase local biodiversity of cliff-nesting animals by incrementing the availability of holes for secondary cavity-nesting species through their burrowing activity (Hansell 1993).

In Spain, there are three burrowing species that can be easily found in mining sites: rabbits (*Oryctolagus cuniculus*), European Bee-eaters (*Merops apiaster*) and Sand Martins. All of them construct elevated numbers of burrows that are used by secondary user species. Casas-Crivillé & Valera (2005) recorded 19 species of vertebrates and several invertebrate species that occupy abandoned European Bee-eater burrows. Galvez Bravo et al. (2009) reported over 15 species of vertebrates that use rabbit

burrows. Mead & Pepler (1975) detected 16 bird species nesting in Sand Martin burrows in a study at a national scale in Great Britain.

Sand Martins are considered to be engineer species, which are species that affect other organisms by modulating the availability of resources to other species (Jones et al. 1994). There are examples of engineer species that can help revert impacts on degraded ecosystems through the ecosystem services they provide. For example, in the temperate woodlands in Australia, the Eastern Bettong (*Bettongia gaimardi*) can have profound effects on water infiltration and seed germination with its burrowing activity, helping restore the degraded woods (Manning et al. 2001). Another example are Cyanobacteria, which can contribute to the recovery of ecosystem functions such as erosion resistance and nutrient cycling through the formation of biological soil crusts in degraded drylands (Chiquoine et al. 2016).

However, despite the awareness of the relevance of the services provided by engineer species, the ecosystem engineering concept has been rarely included in habitat improvement, conservation and ecological restoration projects (Byers et al. 2006). Furthermore, there are also very few studies regarding the secondary cavity-nesting species of Sand Martin burrows and their relevance towards them in Mediterranean areas.

Sand Martins could be a good model to study potential environmental services of birds in mining restoration because they could facilitate the colonization of mining sites by other cliff-nesting species and enhance local biodiversity. Therefore, studying how to promote Sand Martins in mining sites and learn how to reconcile their presence in mining sites with mining activity, could benefit not only this threatened species, but it could potentially help increase local biodiversity as well through its burrowing activity.

Opportunities to advance in ecology and restoration sciences

This work is an opportunity to advance in the fields of ecology and restoration. Our study allows us to explore novel ways of undertaking mining restoration, which we cannot completely tackle with our current knowledge, and which *business-as-usual* approaches do not always manage to fulfil. In addition, this research took place due to a unique opportunity, where the academic sector worked hand in hand with the private sector to address solutions for environmental issues that affect our societies globally. This type of partnership can be very advantageous to develop research projects, by enriching them with the benefits and contributions of their different perspectives and knowledge (e.g. access to machinery, financial support or technical expertise in the case of the private sector, and scientific knowledge, experimental design and data analysis in the case of the academic sector).

Mining sites offer a novel scenario to study the response of organisms to changes in the structural habitat, as cliff environments are generated as a consequence of the mining activity itself. The scenario mining sites create, allows to experiment by manipulating habitats with low costs, unlike in other fields such as forest restoration, where the possibilities of habitat manipulation are more difficult, or where equivalent structures require much more time to obtain, for example large trees. Therefore, the mining context allows to manipulate cliff habitats, study the organisms' responses, and analyze the possibility of generating habitats when restoring these areas. Restored areas can turn into trap habitats because they can attract individuals to places that do not benefit them in the long run. It has been demonstrated that trap habitats are generated more frequently in anthropogenic habitats (Roberston and Hutto 2006, Roberston

et al. 2013). The recent or sudden environmental changes in evolutionary terms, act to uncouple the cues that individuals use to assess habitat quality. This generates maladaptive responses from the animals and they may feel attraction to relatively bad habitats.

Regarding restoration ecology, the line of research that we intend to develop through this PhD Thesis does not aim to transform how mining sites are restored, but rather to explore the possibilities cliff environments can offer. For example, when mining activity begins in very degraded areas by other human activities, the restoration of these areas opens an opportunity to restore local biodiversity. Using cliff-nesting birds as target species, comprehensive restoration plans can be designed, where rocky environments would occupy specific areas with ecological interest (e.g. areas colonized by protected species, or colonized by a rich and large community of cliff-nesting species), and the rest of the requirements for these target species, such as foraging and roosting areas, would create a heterogeneous space that could benefit many other species.

OBJECTIVE AND STRUCTURE

The general objective of this work is to study how to improve local biodiversity in mining sites (open cast mines – quarries and aggregate pits – belonging to the construction industry) by improving the habitats for cliff-nesting bird species. By studying the cliff-nesting bird communities in these industrial areas, and studying factors that regulate their presence, abundance and breeding habitat preferences, we aim to provide tools with which to help practitioners in mining sites to manage the biodiversity at their sites and reconcile the presence of these communities with the mining activity, both during the active and restoration phases.

This PhD Thesis is structured in seven sections: 1) a general introduction which highlights the framework of this study, 2) four research chapters, which analyze a specific aspect of the objectives; one of them is presented as a descriptive chapter about the cliff-nesting bird community at mining sites and three of them are shown as separate scientific publications; 3) a general discussion which synthesizes the work and main results, links the different chapters, and suggests new lines of future research; 4) conclusions of the research.

The specific objectives were the following (Table I.2).

Chapter II. Description of cliff-nesting bird communities in mining sites in central and East Spain

General objective:

To study the species abundance, richness and diversity of cliff-nesting birds in mining sites. For this, we carried out a field survey of cliff-nesting bird communities in mining sites at a nation-wide scale. This study will serve as a basis to propose future actions aimed at promoting biodiversity in mining sites and to identify model species for species-level studies.

Specific objectives:

1. To study abundance and species richness of the cliff-nesting birds in the mining sites.
2. To describe the main characteristics of the species that form the cliff-nesting communities, including the taxonomic group, trophic ecology, breeding behavior (colonial or territorial breeders), burrower species, the type of substrates they nest in, and their protection status at national and regional level.

Table 1.2 Summary of objectives and material and methods (study area, scales, statistical analyses) of the four research chapters (Chapters II, III, IV, V).

Chapter	Objective	Study area	Scales	Statistical analyses
Chp II. Cliff-nesting bird communities	Study the cliff-nesting communities present at the mining sites, their abundance, richness and diversity. Describe main characteristics of the species which form the communities.	28 mining sites in central and East Spain	Mining site scale: surface occupied by the mining sites and 1 km buffer	
Chp III. Cliff-nesting bird predators	Study the presence and diet of a large nocturnal cliff-nesting top predator - the Eagle Owl - at the mining sites, and determine the effect of this predator on the cliff-nesting bird community.	28 mining sites in central and East Spain 11 mining sites in central Spain	28 mining sites: Colonization of mining sites by the Eagle Owl 11 mining sites: Diet of the Eagle Owl	Man-Whitney U-tests and t-tests (effect of Eagle Owl presence on cliff-nesting bird communities and rabbit abundance) Pearson and Spearman correlations (comparison of Eagle Owl diet with cliff-nesting bird communities and rabbit abundance)
Chp IV. Cliff-nesting burrowing species	Study the presence, abundance and breeding habitat preferences of the Sand Martin at mining sites, and develop management and restoration recommendations for the aggregate sector.	28 mining sites in central and East Spain 10 mining sites in Madrid (28 colonies) 10 mining sites in Madrid (28 colonies)	Mining site scale: surface of mining sites and 1 km buffer Colony scale: Vertical faces where colonies were located Burrow scale: 232 sampling points on the vertical faces of the colonies	Generalized linear mixed models (GLMMs) (analyze habitat preferences at the three studied scales)
Chp V. Secondary user cliff-nesting species	Study the abundance, richness and occupation rates of cliff-nesting secondary user birds that occupy Sand Martin burrows to breed, so as to promote self-regulating cliff-nesting communities at the mining sites.	10 mining sites in Madrid (30 colonies)	30 colonies: vertical faces with burrows were Sand Martin colonies were located	Generalized Linear Mixed Models (GLMM) (detect factors affecting secondary cavity-nesting species' abundance and richness, and occupation rate of Sand Martin burrows)

Hypothesis:

We expect that mining sites will be colonized by breeding cliff-nesting birds and that the cliff-nesting communities will be formed by a variety of bird groups, nesting both in the rocky and sandy substrates.

Chapter III. Eagle Owl presence and diet at mining sites: Implications for restoration and management for cliff-nesting birds

General objective:

To study potential trap habitats by excess of predation in mining sites. Specifically, to analyze the capacity of the Eagle Owl to generate ecological traps in mining sites and outline restoration and management considerations for cliff-nesting birds to avoid an excess of predation pressure.

Specific objectives:

1. To estimate the presence and abundance of Eagle Owls in the mining sites.
2. To study the Eagle Owl's diet in the mining sites through pellet analysis.
3. To estimate rabbit abundance (the main prey of the Eagle Owl) in the mining sites.
4. The results of the diet will be related to the abundance of rabbits and cliff-nesting birds in the mining sites.
5. The results will help incorporate management practices for the Eagle Owls in the mining sites to reduce the risk of predation on cliff-nesting birds.

Hypothesis:

The Eagle Owl is a top predator, which feeds mainly on rabbits, but can diversify its diet including birds, depending on the availability of its main prey. This species colonizes mining sites frequently in the study area. This could

generate an ecological trap for the rest of the cliff-nesting birds due to excessive predation. A lower abundance of rabbits in the mining sites is expected to increase the pressure of the Eagle Owl on cliff-nesting birds.

Chapter IV. Restoration and management for cliff-nesting birds in Mediterranean mining sites: The Sand Martin case study

General objective:

To study breeding habitat selection and preferences of cliff-nesting birds at mining sites at several spatial scales. Specifically, to increase the knowledge of the ecology and reproductive biology of the Sand Martin (a burrowing cliff-nesting species) in mining sites in Spain, and establish measures to reconcile mining activity with their breeding populations in said spaces.

Specific objectives:

1. To analyze the relevance of mining sites as breeding habitats for the Sand Martin in Spain.
2. To study breeding habitat preferences of the Sand Martin in the mining sites at three spatial scales: 1) landscape scale (the surface of the mining site and 1 km buffer around the mining sites), 2) colony scale (vertical faces where the colonies are located) and 3) burrow scale. Studied variables include variables related with feeding habitats (such as distance to water or surface of pastures) and nesting structures (such as length of the faces, or percentage of vegetation cover).
3. To study the reproductive biology of the Sand Martin at the mining sites.
4. To establish some management guidelines for the Sand Martin in mining sites to help reconcile the breeding populations and the mining activity.

Hypothesis:

Mining sites can exert a strong attraction on some cliff-nesting species during the reproductive period. In these cases, the management of the mining sites can determine the reproductive success and viability of the breeding populations. Therefore, it is necessary to establish guidelines that help mining site operators manage these species during the breeding season. We expect Sand Martins to show habitat preferences at different scales: at the landscape scale preferring areas closer to their natural breeding habitats (lentic water and rivers), and at the colony and burrow scales being influenced by different morphological features of the nesting structures (such as length, height and slope).

Chapter V. Bird services applicable to mining restoration: The Sand Martin (*Riparia riparia*) burrow construction case study

General objective:

To study the engineering activities and ecosystem services of cliff-nesting birds at mining sites. Specifically, to study the availability of burrows of biotic origin in mining sites, and their possible role in improving the local biodiversity of cliff-nesting birds.

Specific objectives:

1. To estimate Sand Martin burrow abundance and Sand Martin occupation rate in mining areas.
2. To identify secondary cavity-nesting birds using Sand Martin burrows and their burrow occupation rates.
3. To study the dynamic of Sand Martin burrows in the colonies by estimating the annual construction and disappearance rates of burrows.
4. To determine factors that favor burrow occupation by secondary cavity-nesting

species, related with Sand Martin activity and presence (such as abundance or availability of burrows), and with characteristics of the faces (such as the type of structure where the colony is located -vertical extraction face or stockpile- or the age of the face).

Hypothesis:

The abundance of holes may be a limitation for the colonization of secondary cavity cliff-nesting birds at mining sites and the burrowing activity of the Sand Martin may increase the availability of holes for these species. We expect Sand Martin burrows to be colonized by secondary users, and that factors that could affect secondary occupation are: a) Sand Martin abundance, which would affect positively by providing other advantages to the secondary cavity-nesting species such as group defense against predators; b) Burrow abundance, which would affect positively because areas with more burrows could attract more secondary cavity-nesting species; c) The type of structure where the colony is located (vertical extraction face or stockpile), since each type of structure may differ in the amount of available holes from other origins, such as mining activity; d) The age of the structure, which could also affect positively, conditioning the available time for Sand Martins and secondary cavity-nesting species to colonize the structures.

REFERENCES

- Bachmann S, Haller B, Lötscher R, Rehsteiner U, Spaar R, Vogel C (2008) *Guide de promotion de l'hirondelle de rivage en Suisse. Conseils pratiques pour la gestion des colonies dans les carrières et la construction de parois de nidification*. Fondation Paysage et Gravier, Uttigen, Association Suisse de l'industrie des Graviers et du Béton, Berne, Association Suisse pour la Protection des Oiseaux ASPO/BirdLife Suisse, Cudrefin, Station ornithologique suisse, Sempach, Switzerland https://www.landschaftundkies.ch/cvfs/4754366/VFS-DFA-1268597-leitfaden_uferschwalbe_fr.pdf (accessed 4

- February 2017)
- Battin J (2004) Bad habitats: Animal ecological traps and the conservation of populations. *Society for Conservation Biology* **18**:1482–1491
- BirdLife International (2016) *Riparia riparia*. The IUCN Red List of Threatened Species 2016. e.T103815961A87438023. <http://dx.doi.org/10.2305/IUCN.UK.2016-3.RLTS.T103815961A87438023.en>. (accessed 25 March 2019)
- Boyce A, Fisher L, Lehman WE, Hipp B, Peterson J (1980) Prairie falcons nest on an artificial ledge. *Raptor Research* **14**:46–50
- Bradshaw A (1984) Ecological principles and land reclamation practice. *Landscape Planning* **11**:35–48
- Bradshaw A (1996) Underlying principles of restoration. *Canadian Journal of Fisheries and Aquatic Sciences* **53**:3–9
- Brambilla M, Rubolini D, Guidali F (2006) Factors affecting breeding habitat selection in a cliff-nesting peregrine Falco peregrinus population. *Journal of Ornithology* **147**:428–435
- Brambilla M, Bassi E, Ceci C, Rubolini D (2010) Environmental factors affecting patterns of distribution and co-occurrence of two competing raptor species. *Ibis* **152**:310–322
- Bullock JM, Aronson J, Newton AC, Pywell RF, Rey-Benayas JM. (2011) Restoration of ecosystem services and biodiversity: Conflicts and opportunities. *Trends in Ecology and Evolution* **26**:541–549
- Burke T (2017) Bank Swallow (*Riparia riparia*) breeding in aggregate pits and natural habitats. M.Sc. Graduate Program, Trent University, Peterborough, Ontario, Canada https://digitalcollections.trentu.ca/objects/etd-553?solr_nav%5Bid%5D=83ffe292b575573596ff&solr_nav%5Bpage%5D=0&solr_nav%5Boffset%5D=0 (accessed 10 October 2018)
- Casas-Crivillé A, Valera F (2005) The European bee-eater (*Merops apiaster*) as an ecosystem engineer in arid environments. *Journal of Arid Environments* **60**:227–238
- Castillo I, Elorriaga J, Zuberogoitia I, Azkona A, Hidalgo S, Astorkia L, Iraeta A, Ruiz F (2008) Importancia de las canteras sobre las aves rupícolas y problemas derivados de su gestión. *Ardeola* **55**:103–110
- Cockle KL, Martin K, Drever MC (2010) Supply of tree-holes limits nest density of cavity-nesting birds in primary and logged subtropical Atlantic forest. *Biological Conservation* **143**:2851–2857
- Cooke JA, Johnson MS (2002) Ecological restoration of land with particular reference to the mining of metals and industrial minerals: A review of theory and practice. *Environmental Reviews* **10**:41–71
- Cramp S (1988) *Handbook of the birds of Europe, the Middle East and North Africa. The birds of the Western Palearctic*. Oxford University Press, Oxford, United Kingdom
- Dalbeck L, Heg D (2006) Reproductive success of a reintroduced population of Eagle Owls *Bubo bubo* in relation to habitat characteristics in the Eifel, Germany. *Ardea* **94**:3–21
- Donázar JA, Ceballos O, Fernández C (1989) Factors influencing the distribution and abundance of seven cliff-nesting raptors: A multivariate study. Pages 45–552. In: Meyburg, BU & Chancellor, RD (eds). *Raptors in the Modern World*. WWGGBP, Berlin, London and Paris
- Donovan TM, Thompson III FR (2001) Modeling the ecological trap hypothesis: A habitat and demographic analysis for migrant songbirds. *Ecological Applications* **11**:871–882
- Ekroos J, Öst M, Karell P, Jaatinen K, Kilpi M (2012) Philopatric predisposition to predation-induced ecological traps: Habitat-dependent mortality of breeding eiders. *Oecologia* **170**:979–986
- Etxezarreta J (2010) Distribución y situación actual del avión zapador (*Riparia riparia*) en la Vertiente Cantábrica del País Vasco. *Munibe (Ciencias Naturales-Natur Zientziak)* **58**:149–171
- Gahbauer MA, Bird DM, Clark KE, French T, Brauning DW (2015) Productivity, mortality, and management of urban peregrine falcons in northeastern North America. *Journal of Wildlife Management* **79**:10–19
- Galvez Bravo L, Belliure J, Rebollo S (2009) European rabbits as ecosystem engineers: Warrens increase lizard density and diversity. *Biodiversity and Conservation* **18**:869–885
- García D (2009) Spatial and temporal patterns of the Bank Swallow on the Sacramento River. M.Sc. in Environmental Science, California State University, California, USA http://csuchico-dspace.calstate.edu/bitstream/handle/10211.3/10211.4_85/9%204%202009%20Dawn%20Garcia.pdf?sequence=5 (accessed 20 October 2018)
- Girvetz EH (2010) Removing erosion control projects increases bank swallow (*Riparia riparia*) population

- viability modeled along the Sacramento River, California, USA. *Biological Conservation* **143**:828–838
- Gulickx MMC, Beecroft R, Green A (2007) Creation of artificial sand martin *Riparia riparia* burrows at Kingfishers Bridge, England. *Conservation Evidence* **4**:51–53
- Hale R, Swearer SE (2017) When good animals love bad restored habitats: How maladaptive habitat selection can constrain restoration. *Journal of Applied Ecology* **54**:1478–1486
- Hansell MH (1993) The ecological impact of animal nests and burrows. *Functional Ecology* **7**:5–12
- Hawlena D et al. (2010) Ecological trap for desert lizards caused by anthropogenic changes in habitat structure that favor predator activity. *Conservation Biology* **24**:803–809
- Heneberg P (2005) The only native nesting place of the Sand Martin (*Riparia riparia*) in Central Bohemia – influence of floods and predation. *Sylvia* **41**:112–118
- Heneberg P (2007) Sand martin (*Riparia riparia*) in the Czech Republic at the turn of the millenium. *Linzer Biologische Beiträge* **39**:293–312
- Jones CG, Lawton JH, Shachak M (1994) Organisms as ecosystem engineers. *Oikos* **69**:373–386
- Lamb D, Erskine PD, Parrotta JA (2005) Restoration of degraded tropical forest landscapes. *Science* **310**:1628–1632
- Madroño A, González C, Atienza J (2004) *Libro Rojo de las Aves de España*. Dirección General para la Biodiversidad, SEO/BirdLife, Madrid, Spain
- Mänd R et al. (2009) Provision of nestboxes raises the breeding density of great tits *Parus major* equally in coniferous and deciduous woodland. *Ibis* **151**:487–492
- Marchesi L, Sergio F, Pedrini P (2002) Costs and benefits of breeding in human-altered landscapes for the Eagle Owl *Bubo bubo*. *Ibis* **144**:E164–E177
- Martínez JA, Serrano D, Zuberogoitia I (2003) Predictive models of habitat preferences for the Eurasian eagle owl: a multiscale approach. *Ecography* **26**:21–28
- Mborah C, Bansah KJ, Boateng MK (2015) Evaluating alternate post-mining land-uses: A review. *Environment and Pollution* **5**:14–22
- Mead CJ, Pepler (1975) Birds and other animals at Sand Martin colonies. *British Birds* **68**:89–99
- Moffatt KC, Crone E, Holl KD, Schlorff RW, Garrison BA (2005) Importance of hydrologic and landscape heterogeneity for restoring bank swallow (*Riparia riparia*) colonies along the Sacramento River, California. *Restoration Ecology* **13**:391–402
- Noguera M, Aute FX, Santaefemia FX (2014) Situació del Còlit negre *Oenanthe leucura* al massís del Garraf i paper de les pedreres costaneres en la seva conservació. *Revista Catalana d'Ornitologia* **30**:41–53
- Norriss DW (1995) The 1991 survey and weather impacts on the peregrine *Falco peregrinus* breeding population in the Republic of Ireland. *Bird Study* **42**:20–30
- OMNRF (Ontario Ministry of Natural Resources and Forestry) (2017) Best Management Practices for the Protection, Creation and Maintenance of Bank Swallow Habitat in Ontario. Queen's Printer for Ontario, Ontario, Canada <https://www.ossqa.com/multimedia/2017-03-27-100504-95129/bansbmpenpdffinal.1.117mar17.pdf> (accessed 24 October 2017)
- Ostlyngen A, Johansen K, Halvorsen P (2011) Artificial nests - A remedial action in maintaining viable Gyrfalcon populations? Pages 349–362. In: Watson RT, Cade TJ, Fuller M, Hunt G, Potapov E (eds). *Gyrfalcons and Ptarmigan in a Changing World*, Vol. II. The Peregrine Falcon Foundation, Boise
- Page JE (1989) Use of explosives to enhance a Peregrine falco eyrie. *Journal Raptor Research* **23**:176–178
- Poysa H, Poysa S (2003) Nest-site limitation and density dependence of reproductive output in the common goldeneye *Bucephala clangula*: Implications for the management of cavity-nesting birds. *Journal of Applied Ecology* **39**:502–510
- Rebollo S (2016) Mejora de hábitats para la fauna ¿creando hábitats fuente o trampas ecológicas? In: *Libro de resúmenes III Congreso Colombiano de Restauración Ecológica*. Rionegro, Colombia.
- Ritchie RJ, Doyle TJ, Wright JM (1998) Peregrine Falcons (*Falco peregrinus*) nest in a quarry and on highway cutbanks in Alaska. *Journal of Raptor Research* **32**:261–264
- Roberston BA, Hutto RL (2006) A Framework for understanding ecological traps and an evaluation of existing evidence. *Ecology* **87**:1075–1085.
- Robertson BA, Rehage JS, Sih A (2013) Ecological novelty and the emergence of evolutionary traps. *Trends in*

- Ecology & Evolution* **28**:552-560
- Rodenhouse NL, Sherry TW, Holmes RT (1997) Site-dependent regulation of population size: A new synthesis. *Ecology* **78**:2025–2042
- SCV (Sociedad para la Conservación de Vertebrados) (1999) Situación actual del avión zapador (*Riparia riparia*) en la comunidad de Madrid. Pages 72–77. In: SEO-Monticola (ed) *Anuario Ornitológico de Madrid*, Madrid, Spain
- SCV (Sociedad para la Conservación de Vertebrados) (2007) Censo de avión zapador (*Riparia riparia*) en la Comunidad de Madrid, Madrid, Spain <https://scv-conservacion.webcindario.com/avionzapador/zapador2007.html> (accessed 1/8/2018).
- Sekercioglu C (2006) Increasing awareness of avian ecological function. *Trends in Ecology & Evolution* **21**:464–471
- SER (Society for Ecological Restoration International Science & Policy Working Group) (2002) The SER Primer on Ecological Restoration. SER Science & Policy Working Group. www.ser.org (accessed 17 November 2017)
- SER (Society for Ecological Restoration International Science & Policy Working Group) (2004) The SER International primer on ecological restoration. https://www.ctahr.hawaii.edu/littonc/PDFs/682_SERPrimer.pdf (accessed 26 March 2019)
- Soler M (2014) Grajilla – *Corvus monedula* Linnaeus, 1758. In: Salvador A, Morales MB, (eds). *Enciclopedia Virtual de los Vertebrados Españoles*. Museo Nacional de Ciencias Naturales, Madrid.
- UEPG (2019) *European Aggregates Association Annual Review 2017-2018*. Pages 1–32 <http://www.uepg.eu/uploads/Modules/Publications/uepg-annual-review-2017-2018.pdf> (accessed 25 March 2019)
- Wenny DG, DeVault TL, Johnson MD, Kelly DH, Sekercioglu C, Tomback DF, Whelan CJ (2011) The need to quantify ecosystem services provided by birds. *The Auk* **128**:1–14
- Whelan CJ, Wenny DG, Marquis RJ (2008) Ecosystem services provided by birds. *Annals of the New York Academy of Sciences* **1134**:25–60
- Wright DH, Lomeli H, Hofmann PS, Nguyen C (2011) Burrow occupancy and nesting phenology of bank swallows along the Sacramento river. *California Fish and Game* **97**(3):138–147
- Zuberogitia I, Campos LF, Crespo T, Ocio G. (1994) Situación y datos sobre la reproducción de las rapaces nocturnas en Bizkaia. Pages 297–305. In: *Actas de las XII Jornadas Ornitológicas Españolas*. Almerimar (El Ejido-Almería), Spain





CHAPTER II

Description of cliff-nesting bird communities in mining sites in central and East Spain

CHAPTER II

Description of cliff-nesting bird communities in mining sites in central and East Spain

BACKGROUND

Birds that rely primarily on rocky or sandy walls to breed are known as cliff-nesting birds (Donázar et al. 1989; Brambilla et al. 2006). Cliff-nesting birds have been able to adapt to anthropogenic environments, such as mining sites like quarries and aggregate pits (Moore et al. 1997; Ritchie et al. 1998; Gahbauer et al. 2015), if these meet their ecological needs (Ritchie et al. 1998; Marchesi et al. 2002). The faces of stone quarries are often used as breeding sites by raptors (Dalbeck & Heg 2006; Marchesi et al. 2002; Zuberogoitia et al. 1994; Brambilla et al. 2006), corvids (Soler 2014), or different passerines (Noguera et al. 2014), and the sandy faces of aggregate pits are frequently used by burrowing cliff-nesting species, such as Sand Martins (*Riparia riparia*) (Burke 2017).

Birds can colonize mining sites in short periods of time, even when mining sites are active. There are even cases where restored mining sites have acquired biological interest, to the point of having been included in nature reserves (Lundholm & Richardson 2010). Over the last decades, cliff-nesting birds have been increasingly breeding in mining sites, and some species have important proportions of their populations in these anthropic sites (Zuberogoitia et al. 1994; Norriss 1995; SCV 1999; Castillo et al. 2008). This situation raises a scientific discussion regarding the use of mining sites by cliff-nesting birds and encourages studying ecological bases for cliff-nesting bird management.

There is a debate around whether the unique circumstances created in mining sites, such as

the rocky and sandy artificial cliffs, the fenced areas with limited access, etc. can produce areas which can be richer in wildlife than some of the remaining rural or urban environments. Some mining sites could replace areas or habitats that are disappearing, and the adaptation to these anthropogenic areas could enable some rare species to subsist and prevent other common species from becoming scarce (Lundholm & Richardson 2010). The availability of suitable nest sites is one of the most important limiting factors for breeding density in birds (Aitken et al. 2002; Brambilla et al. 2006). There are examples where occupation of natural nesting cliffs reached saturation point, making individuals resort to artificial cliffs, mainly in quarries (Crick & Ratcliffe 1995; Dalbeck & Heg 2006). On the other hand, mining sites also produce areas that are very different to their surroundings, providing heterogeneity and habitats that might not have been previously present in the area, such as the afore mentioned cliffs, ruderal habitats or wetlands, that could complement as breeding and feeding habitats for birds (Lundholm & Richardson 2010; Noguera et al. 2014).

Though there are studies regarding cliff-nesting birds that colonize mining sites, they are mostly centered on one species (Crick & Ratcliffe 1995; Moore et al. 1997; Ritchie et al. 1998; Noguera et al. 2014; Burke 2017) and there is a lack of studies that analyze the cliff-nesting communities as a whole.

Our objective in this chapter was to study the richness, abundance and diversity of breeding cliff-nesting birds at mining sites. We also wanted to study the characteristics of the

species that colonized the mining sites, such as their conservation status, breeding behavior (colonial or territorial breeders), taxonomic groups (raptors, sparrows, wheatears, corvids, etc.), materials they nest in the most (rock or sand cliffs) and whether they were burrowers or not. Understanding what cliff-nesting birds colonize mining sites, in what numbers, and their ecological characteristics, can provide ecological bases for the management of these species and for the selection of case study species for further analysis in order to help reconcile the presence of cliff-nesting birds in the mining sites with the industrial activity and help develop restoration plans that benefit these species.

Considerations of the study

The study of the cliff-nesting bird communities took place in 2016 in 28 mining sites (including quarries and aggregate pits) located in central and East Spain (Figure 2.1). The climate of the study area is Mediterranean, with the

precipitation ranging between 320 to 675 mm. The mean annual temperature varied from 10 to 18°C and with an increasing temperature gradient from the center to the East.

The selected mining sites were characteristic of the study area and covered the largest possible range of conditions, including the size of the mining sites, inactivity (defined as the years passed since mining activity occurred at the site, and where 0 indicates active sites) and age of the mining site (years passed since the mining sites were opened) (Table 2.1). The type of extracted material also varied and was related with the type of extraction that took place: either for cement or for aggregates, and by blasting which produces rocky cliffs (quarries) or by directly scraping the material, which produces sandy cliffs (aggregate pits) (Table 2.1). The mean lengths and heights of cliffs at the mining sites also varied, as well as the total surface of cliffs present at each mining site.

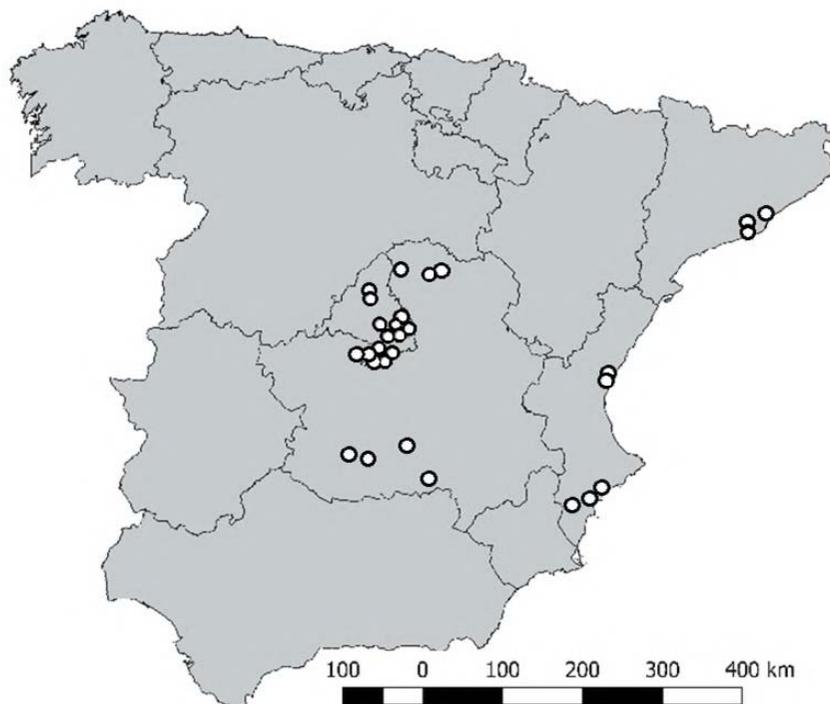

Figure 2.1 Location of the 28 mining sites in central and East Spain where surveys of cliff-nesting birds were carried out.

Table 2.1 Descriptive variables for each of the 28 studied mining sites: Type of extraction (aggregate quarry, aggregate pit and cement quarry), extracted material, age of the mining site (years passed since industrial activity commenced at the site), inactivity (years passed since mining activity took place at the mining site), size of the mining sites (ha), mean cliff height and length of the cliffs present at the mining site (m), total cliff surface at the mining site (m²), surface of forests, shrublands, agriculture, pastures, extractive industry and artificial areas in 1 km buffer (ha %), distance to water bodies in 1 km buffer (m; 1000 m indicate no presence, 0 indicates presence in the mining site), mean annual precipitation (mm), mean annual temperature (°C), altitude (m above sea level). Mining sites are ordered alphabetically.

Mining site	Type of extraction	Extracted material	Age (y)	Inactivity (y)	Size of mining site (ha)	Mean cliff length (m)	Mean cliff height (m)	Total cliff surface (m ²)	Surface of forests (%)	Surface of shrublands (%)	Surface of agriculture (%)	Surface of pastures (%)	Surface extractive industry (%)	Surface of artificial areas (%)	Distance to water bodies (m)	Precipitation (mm)	Temperature (°C)	Altitude (m)
ALM	Aggregate quarry	Limestone	57	0	39	260	7	33512	1	6	51	41	1	0	1000	434	17	150
CER	Aggregate quarry	Limestone	57	0	38	113	6	17175	56	29	0	0	5	10	1000	675	14.5	500
COR	Aggregate pit	Sand	11	6	34	93	10	19979	0	10	84	0	5	1	40	444	13.5	525
CTO	Cement quarry	Limestone	30	9	84	98	8	24514	16	0	61	10	0	13	805	441	13.6	720
DOL	Cement quarry	Pozzolan	30	12	15	136	6	6433	0	0	63	32	5	0	518	437	14.8	650
EBU	Aggregate quarry	Limestone	28	3	33	173	7	47239	5	4	23	67	1	0	1000	344	18.1	350
EMA	Aggregate quarry	Limestone	35	12	23	75	7	12775	35	19	27	15	4	0	1000	416	12.9	1100
EMO	Aggregate quarry	Limestone	27	7	23	110	9	39808	24	0	62	0	14	0	252	450	13.7	790
EPU	Aggregate pit	Sand	30	5	189	168	6	18433	0	0	45	31	15	6	0	401	14.9	500
ESP	Aggregate quarry	Limestone	30	8	24	102	9	28994	28	0	47	0	25	0	89	450	13.7	790
FON	Aggregate quarry	Limestone	49	0	53	182	9	126144	0	19	10	62	2	7	1000	344	18.1	220
GAR	Aggregate quarry	Limestone	57	0	63	145	6	59368	1	84	0	0	11	4	1000	594	16.6	200
LCH	Aggregate quarry	Limestone	14	10	21	101	8	4676	0	40	57	3	0	0	0	450	13.7	840
LPO	Aggregate quarry	Granite	42	4	30	187	10	30684	0	6	0	70	7	17	0	524	10.2	830
LSO	Aggregate quarry	Limestone	33	0	52	174	12	40773	0	13	60	26	1	0	1000	448	14.1	755
MON	Cement quarry	Limestone	57	0	42	132	5	4430	14	24	0	7	2	53	328	612	16.5	150
MOS	Cement quarry	Gypsum	32	0	12	91	6	4811	0	5	63	27	5	0	1000	415	14.3	600
OFR	Aggregate quarry	Limestone	43	0	36	139	13	43358	0	8	22	59	3	8	1000	318	17.8	450
OLI	Aggregate quarry	Limestone	27	6	4	122	8	9084	14	1	55	0	30	0	150	450	13.7	790
PRE	Aggregate pit	Sand	37	7	25	28	3	350	0	6	14	58	17	5	0	437	14.1	550
REM	Aggregate quarry	Porphyry	37	22	10	236	7	3068	0	0	0	99	0	1	0	524	10.2	1000
RET	Aggregate quarry	Limestone	42	17	3	198	12	6803	65	23	11	0	0	0	100	469	10.3	992
ROM	Aggregate pit	Sand	30	0	101	65	2	15159	1	1	53	9	28	6	0	415	14.6	520
SCA	Cement quarry	Pozzolan	11	0	7	92	4	6915	0	0	69	31	0	0	1000	443	14.7	750
SLL	Cement quarry	Limestone	67	0	63	178	4	22318	43	7	42	5	0	2	1000	441	17	200
TER	Aggregate quarry	Limestone	34	8	6	41	7	2850	0	5	71	24	0	0	495	474	13.4	870
VIL	Cement quarry	Clay	67	0	103	102	13	3948	0	10	86	0	0	4	1000	415	14.3	615
YEP	Cement quarry	Limestone	87	0	523	127	5	35723	4	11	63	16	6	0	0	441	13.6	700

Around the mining sites in 1 km buffer there was extractive activity in 71% of the sites, 75% had shrublands, and 93% had agriculture and/or pastures and grasslands (0 indicates no surface present). More than half the sites (57%) had water bodies (lentic or running) in the 1 km buffer (0 indicates presence of water bodies in the mining site, 1000 indicates no water bodies present) (Table 2.1).

The years passed since mining activity occurred at the site was obtained through interviews with quarry managers. Land use information and geographical variables were obtained through Corine Land Cover (Instituto Geológico Nacional 2012) and measured with QGIS (QGIS Development Team 2016).

The original design for this survey considered to study the natural cliff habitats located in the surrounding of the mining sites as reference systems, and compare the cliff-nesting communities between both systems. However, this paired design had to be discarded due to the absence of natural cliff habitats with similar geological and geomorphological contexts in the proximity of many mining sites.

We considered cliff-nesting birds as the species indicated to nest in cliffs in the atlas for reproductive birds of Spain, even if not exclusively, such as the Little Owl (*Athene noctua*) (Martí & Moral 2003). Visits to the mining sites (one visit per mining site) were conducted during breeding period, from May to July (Martí & Moral 2003). The richness (number of species) and abundance (total number of individuals) of cliff-nesting birds in the mining sites was estimated through surveys on foot which covered the area completely (800 to 8000 m which lasted between 2 to 4 hours, according to surface of the mining sites) and allowed visual inspection of all cliff environments. We counted all individuals detected by sight and sound, avoiding double counts when individuals

were seen several times at the same location, or located in an area already surveyed. Surveys were carried out during the first hours of the day and in favorable weather. Once the number of cliff-nesting species and individuals was obtained, Shannon diversity and the frequency (percentage of appearance) at the mining sites was calculated for the surveyed species.

Observations

We detected cliff-nesting birds in all the 28 studied mining sites, with abundance ranging from 25 to 687 individuals per mining site (mean \pm SE = 185 ± 34 per mining site, Figure 2.2). There were more than 100 individuals of cliff-nesting birds in 57% of the mining sites, and the total abundance of cliff-nesting birds in the 28 mining sites was of 5166 individuals. We found a total of 24 cliff-nesting species in the mining sites, which ranged from 3 to 17 species (9 ± 1) per mining site. Only 4 species had fewer than 5 individuals and 42% of the mining sites had 10 or more species. At least 50% of the species were present in 60% of the sites. The diversity (Shannon) ranged between 0.59 to 2.04 (1.43 ± 0.08).

The most abundant species (> 300 individuals) were Rock Sparrows (*Petronia petronia*), Sand Martins, Western Jackdaws (*Corvus monedula*), House Sparrows (*Passer domesticus*), Spotless Starlings (*Sturnus unicolor*), Rock Doves (*Columba livia*), and Common Swifts (*Apus apus*). Regarding their frequency in the mining sites, 32% of the species appeared in at least 50% of the sites, and 18% of the species appeared in less than 10 sites (Figure 2.3).

Approximately 50% of the species were colonial breeders and they concentrated most of the total abundance of cliff-nesting birds (92% of individuals) (Figure 2.3).

The most frequent families were the Muscicapidae which includes wheatears (21%), followed by

Corvidae, Hirundinidae and Passeridae (13% each). Chats and flycatchers (including the three species of wheatears present in Spain) were the most abundant group (21%), followed by crows and jays, sparrows, and swallows and martins (13% each) (Table 2.2).

The majority of the observed species were insectivorous (58%), followed by granivorous species (25%). Raptors accounted for 13% of the species and corvids summed up 4%. Regarding the four species of raptors (two nocturnal and two diurnal), the Common Kestrel (*Falco tinnunculus*) was the most abundant and frequent, followed by the Eagle Owl (*Bubo bubo*). The Eagle Owl is considered to be a super-predator and individuals were in 50% of the sites (Table 2.2), and indications of its presence (individuals or pellets) were observed in 18 (64%) mining sites (Chapter III).

Most of the species (63%) bred in rocky cliffs, both in burrows and ledges or by making mud cups (e.g. Crag martin *Ptyonoprogne rupestris*). The primary cavity nesters which included the two burrowing species (European Bee-eaters (*Merops apiaster*) and Sand Martins) appeared exclusively on sandy substrates (8%). There were species that appeared in both types of cliffs (29%), including the secondary users of Sand Martin burrows, such as the two species of sparrows, the Black Red-starts and even Little Owls. Other species like the European Jackdaws and Common Kestrels appeared in sandy substrates as well, occupying old rabbit warrens that had been left exposed when the cliffs were created by mining. Regarding the conservation status of the cliff-nesting species, three species have minor conservation concern at national level (including two wheatears and the Red-billed Chough *Pyrrhocorax pyrrhocorax*) and 33% of the species are vulnerable at regional level (including the Sand Martin) (Table 2.2).

Remarks

We found cliff-nesting birds in all mining sites studied at a national scale, and at some mining sites these species reached considerable abundance and richness. Cliff-nesting birds were present both in active and inactive mining sites. Some species are threatened at national or regional level, like Choughs and Black Wheatears respectively (Madroño et al. 2004). This confirms that mining sites are extensively used by cliff-nesting birds and that the role of these environments for the management and conservation of these species should be taken into account (see also Lundholm & Richardson 2010).

Among the studied species, two raptors were frequent colonizers of the mining sites: The Common Kestrels and the Eagle Owls. Eagle Owls are considered top predators and super-predators (predators that consume other competing predators, Lourenço et al. 2011). Due to their extended presence at mining sites, the question arises of whether they could exert a strong influence through predation on the cliff-nesting community, if the cliff-nesting birds were to be promoted through habitat improvement actions at mining sites. The potential consequences of top predators for the success of restoration actions for animals is frequently overlooked, though literature indicates that risks through excess of predation occurs in restoration projects (Hale & Swearer 2017). Further studies should be directed at understanding hidden mechanisms that could negatively affect the results of restoration projects for fauna.

Two engineer species were also observed at the mining sites: Sand Martins and the European Bee-eaters. Both are burrowing species that excavate tunnels on vertical sandy substrates, at the end of which they construct their nests. The Sand

Table 2.2 Summarized characteristics of the 24 cliff-nesting bird species observed at the 28 studied mining sites: family, bird group, trophic ecology (Insectivorous = I, Granivorous = G, Carnivorous = C, Omnivorous = O), burrowers (primary cavity nester), type of rocky habitat the species was observed to nest at (rocky or sandy cliffs), conservation status at national level according to the Red Book of Spanish Birds (NE = Not evaluated, DD = Insufficient data, LC = Minor concern, NT = Almost threatened), and whether it has a protected status (vulnerable) at regional level. Species are ordered in decreasing abundance.

Cliff-nesting species	Family	Group	Trophic ecology	Burrower	Habitat	Conservation status national level	Conservation status at regional level
<i>Petronia petronia</i>	Passeridae	Sparrows	I		Rock/Sand	NE	
<i>Riparia riparia</i>	Hirundinidae	Swallows and martins	I	Yes	Sand	NE	yes
<i>Corvus monedula</i>	Corvidae	Crows and jays	G		Rock/Sand	NE	
<i>Passer domesticus</i>	Passeridae	Sparrows	G		Rock/Sand	NE	
<i>Sturnus unicolor</i>	Sturnidae	Starlings	I		Rock	NE	
<i>Columba livia</i>	Columbidae	Pigeons and doves	G		Rock	NE	
<i>Apus apus</i>	Apodidae	Swifts	I		Rock	NE	
<i>Delichon urbicum</i>	Hirundinidae	Swallows and martins	I		Rock	NE	
<i>Merops apiaster</i>	Meropidae	Bee-eaters	I	Yes	Sand	NE	yes
<i>P. montanus</i>	Passeridae	Sparrows	G		Rock/Sand	NE	
<i>Monticola solitarius</i>	Muscicapidae	Chats and flycatchers	I		Rock	NE	yes
<i>Oenanthe leucura</i>	Muscicapidae	Chats and flycatchers	I		Rock	LC	yes
<i>Phoenicurus ochruros</i>	Muscicapidae	Chats and flycatchers	I		Rock/Sand	NE	
<i>Oenanthe oenanthe</i>	Muscicapidae	Chats and flycatchers	I		Rock	NE	
<i>O. hispanica</i>	Muscicapidae	Chats and flycatchers	I		Rock	NT	yes
<i>Falco tinnunculus</i>	Falconidae	Falcons	C		Rock/Sand	NE	
<i>C. oenas</i>	Columbidae	Pigeons and doves	G		Rock	DD	
<i>Pyrrhonorax pyrrhonorax</i>	Corvidae	Crows and jays	O		Rock	NT	yes
<i>Ptyonoprogne rupestris</i>	Hirundinidae	Swallows and martins	I		Rock	NE	
<i>Bubo bubo</i>	Strigidae	Typical Owls	C		Rock	NE	yes
<i>A. pallidus</i>	Apodidae	Swifts	I		Rock	NE	
<i>Athene noctua</i>	Strigidae	Typical Owls	I / C		Rock/Sand	NE	
<i>C. corax</i>	Corvidae	Crows and jays	G		Rock	NE	
<i>F. peregrinus</i>	Falconidae	Falcons	C		Rock	NE	yes

Martin was one of the most abundant species at the mining sites, due in part to its gregarious behavior, and in part because mining sites seem to be increasingly used by this species to breed, to the point that colonies in natural environments seem to be becoming rare in Europe (De Lope et al. 1987; SCV 1999; González 2004; Heneberg 2007; SCV 2007; Etxezarreta 2010). Since mining sites seem to be crucial nesting areas, their management could be critical for the successful reproduction of the Sand Martin (Ruiz de Azua et al. 2003). Future studies that analyze the role these mining environments currently have for the Sand Martins, and how to reconcile their breeding with the industrial activity are crucial for the conservation of this protected species.

Cliffs are generally considered to be ecologically valuable habitats, and some of the cliff-nesting birds have conservation concern (Madroño et al. 2004). However, breeding that takes place in highly anthropogenic habitats is frequently overlooked by the reasons that were explained in the Introduction (Chapter I), such as the influence previous of legislation or lack of technical knowledge on ecological restoration (Castillo et al. 2008). Partnerships between the extractive industry and scientific institutions could help close this knowledge gap, and assist in exploring new restoration alternatives that could be developed in areas of the mining sites that have been colonized during the lifetime of the sites.

Typical mining restoration practices include eliminating the cliffs by reshaping them into smooth slopes (Noguera et al. 2014). Transforming the mining sites into agricultural fields or landfill sites are also widespread practices. These types of project designs usually do not take into consideration the fauna that uses the mining sites to breed, and can even be unfavorable for cliff-nesting species (Castillo et al. 2008; Noguera et al. 2014). Restoration projects

should not disregard the natural assets which appear at mining sites, such as opportunities for conservation and promotion of cliff-nesting birds. Knowledge of detailed habitat requirements could be helpful in designing effective conservation and restoration plans in mining sites (Martínez et al. 2003). It is our belief that it is necessary to extend the concept of mining sites as spaces that can promote local biodiversity, provided that adequate management is carried out.

REFERENCES

- Aitken KEH, Wiebe K, Martin K (2002) Nest-site reuse patterns for a cavity-nesting bird community in Interior British Columbia. *The Auk* **119**:391–402
- Brambilla M, Rubolini D, Guidali F (2006) Factors affecting breeding habitat selection in a cliff-nesting peregrine *Falco peregrinus* population. *Journal of Ornithology* **147**:428–435
- Burke T (2017) Bank Swallow (*Riparia riparia*) breeding in aggregate pits and natural habitats. M.Sc. Graduate Program, Trent University, Peterborough, Ontario, Canada https://digitalcollections.trentu.ca/objects/etd-553?solr_nav%5Bid%5D=83ffe292b575573596ff&solr_nav%5Bpage%5D=0&solr_nav%5Boffset%5D=0 (accessed 10 October 2018)
- Castillo I, Elorriaga J, Zuberogoitia I, Azkona A, Hidalgo S, Astorkia L, Iraeta A, Ruiz F (2008) Importancia de las canteras sobre las aves rupícolas y problemas derivados de su gestión. *Ardeola* **55**:103–110
- Crick HQR, Ratcliffe DA (1995) The peregrine *Falco peregrinus* breeding population of the United Kingdom in 1991. *Bird Study* **42**:1–19
- Dalbeck L, Heg D (2006) Reproductive success of a reintroduced population of Eagle Owls *Bubo bubo* in relation to habitat characteristics in the Eifel, Germany. *Ardea* **94**:3–21
- Donázar JA, Ceballos O, Fernández C (1989) Factors influencing the distribution and abundance of seven cliff-nesting raptors: A multivariate study. Pages 45–552. In: Meyburg, BU & Chancellor, RD (eds). *Raptors in the Modern World*. WWGBP, Berlin, London and Paris
- Etxezarreta J (2010) Distribución y situación actual del avión

- zapador (*Riparia riparia*) en la Vertiente Cantábrica del País Vasco. *Munibe (Ciencias Naturales-Natur Zientziak)* **58**:149–171
- Gahbauer MA, Bird DM, Clark KE, French T, Brauning DW (2015) Productivity, mortality, and management of urban peregrine falcons in northeastern North America. *Journal of Wildlife Management* **79**:10–19
- González JL (2004) El avión zapador (*Riparia riparia*) en Extremadura. Problemática y propuestas de conservación. In: *Congreso sobre especies protegidas en Extremadura*. Trujillo, Spain
- Hale R, Swearer SE (2017) When good animals love bad restored habitats: How maladaptive habitat selection can constrain restoration. *Journal of Applied Ecology* **54**:1478–1486
- Heneberg P (2007) Sand martin (*Riparia riparia*) in the Czech Republic at the turn of the millenium. *Linzer Biologische Beiträge* **39**:293–312
- IGN (Instituto Geológico Nacional) (2012) Centro de Descargas del CNIG. <http://centrodedescargas.cnig.es/CentroDescargas/index.jsp> (accessed 30 August 2017)
- De Lope F, Fernández A, De La Cruz C (1987) La situación del avión zapador (*Riparia riparia*) en Extremadura. *Alytes* **5**:121–132
- Lourenço R et al. (2011) Superpredation patterns in four large European raptors. *Population Ecology* **53**:175–185
- Lundholm JT, Richardson PJ (2010) Habitat analogues for reconciliation ecology in urban and industrial environments. *Journal of Applied Ecology* **47**:966–975
- Madroño A, González C, Atienza J (2004) *Libro Rojo de las Aves de España*. Dirección General para la Biodiversidad, SEO/BirdLife, Madrid
- Marchesi L, Sergio F, Pedrini P (2002) Costs and benefits of breeding in human-altered landscapes for the Eagle Owl *Bubo bubo*. *Ibis* **144**:E164–E177
- Martí R, Moral J (2003) *Atlas de las aves reproductoras de España*. Dirección General de Conservación de la Naturaleza-SEO, Madrid
- Martínez JA, Serrano D, Zuberogoitia I (2003) Predictive models of habitat preferences for the Eurasian eagle owl: a multiscale approach. *Ecography* **26**:21–28
- Moore NP, Kelly PF, Lang FA, Lynch JM, Langton SD (1997) The Peregrine *Falco peregrinus* in quarries: Current status and factors influencing occupancy in the Republic of Ireland. *Bird Study* **44**:176–181
- Noguera M, Aute FX, Santaefemia FX (2014) Situació del Còlit negre *Oenanthe leucura* al massís del Garraf i paper de les pedreres costaneres en la seva conservació. *Revista Catalana d'Ornitologia* **30**:41–53
- Norriss DW (1995) The 1991 survey and weather impacts on the peregrine *Falco peregrinus* breeding population in the Republic of Ireland. *Bird Study* **42**:20–30
- QGIS Development Team (2016) QGIS Geographic Information System. Open Source Geospatial Foundation Project <http://qgis.osgeo.org>
- Ritchie RJ, Doyle TJ, Wright JM (1998) Peregrine Falcons (*Falco peregrinus*) nest in a quarry and on highway cutbanks in Alaska. *Journal of Raptor Research* **32**:261–264
- Ruiz De Azua N, Fernández JM, Bea A, Carreras J (2003) Situación de la población nidificante de avión zapador *Riparia riparia* en Álava. Pages 57–66. In: Diputación Foral de Álava (ed) *Proceedings of the Ornithology Meeting in Álava*. Vitoria-Gasteiz, Spain
- SCV (Sociedad para la Conservación de Vertebrados) (1999) Situación actual del avión zapador (*Riparia riparia*) en la comunidad de Madrid. Pages 72–77. In: SEO-Monticola (ed) *Anuario Ornitológico de Madrid*, Madrid, Spain
- SCV (Sociedad para la Conservación de Vertebrados) (2007) Censo de avión zapador (*Riparia riparia*) en la Comunidad de Madrid, Madrid, Spain <https://scv-conservacion.webcindario.com/avionzapador/zapador2007.html> (accessed 1 August 2018).
- Soler M (2014) Grajilla – *Corvus monedula* Linnaeus, 1758. In: Salvador A, Morales MB, (eds). *Enciclopedia Virtual de los Vertebrados Españoles*. Museo Nacional de Ciencias Naturales, Madrid.
- Zuberogoitia I, Campos LF, Crespo T, Ocio G. (1994) Situación y datos sobre la reproducción de las rapaces nocturnas en Bizkaia. Pages 297–305. In: *Actas de las XII Jornadas Ornitológicas Españolas*. Almerimar (El Ejido-Almería), Spain





CHAPTER III

Eagle Owl presence and diet at mining sites: Implications for restoration and management for cliff-nesting birds

CHAPTER III

Eagle Owl presence and diet at mining sites: Implications for restoration and management for cliff-nesting birds

Rohrer, Z.¹, Rebollo, S.¹, Monteagudo, N.¹, Talabante, C.².

¹Forest Ecology and Restoration Group, Department of Life Sciences, University of Alcalá, 28805 Alcalá de Henares, Madrid, Spain.

²Department of Life Sciences, University of Alcalá, 28805 Alcalá de Henares, Madrid, Spain.

ABSTRACT

The possible consequences of top predators for the success of restoration actions for animals is still poorly understood. Our main objective was to analyze whether there could be a risk of creating habitats with an excess of predation by top predators when carrying out actions to improve cliff habitats for cliff-nesting birds at mining sites. We surveyed 28 mining sites in Spain to obtain information regarding Eagle Owl (*Bubo bubo*) presence and diet, and analyzed their relationship with the abundance of cliff-nesting birds and rabbits (*Oryctolagus cuniculus*, its main prey) at the mining sites. We detected Eagle Owls in 18 mining sites (64%) and collected prey remains in 11 mining sites. A total of 732 minimum number of prey were identified. The diet of the Eagle Owl consisted mainly of mammals (83%) and the proportion of birds in the diet was low (13%). We found there was no relationship between the presence of Eagle Owls and the abundance of rabbits in the mining sites, but there was a positive relationship with the density of cliff-nesting birds. We conclude that the Eagle Owl does not seem to exert a significant pressure on the cliff-nesting birds, even on wild pigeons, the most abundant cliff-nesting species in its diet. Restoration projects that promote cliff-nesting birds would not entail a significant risk of generating ecological traps by excess of predation by the Eagle Owl, and this species could be favored in restoration plans, as it is a threatened species in some areas in Europe.

Key words: *Bubo bubo*, ecological trap, mining restoration, quarries, rupicolous birds, top predators

INTRODUCTION

Predation by top predators can limit the success of habitat enhancement actions for fauna in restoration projects (Hale & Swearer 2017). If the restored habitat is colonized by predators, potential prey colonizing the restored habitat could suffer increased predation that could condition their future viability (Arthur et al. 2010). The restored habitat can even turn into an ecological trap if the individuals are attracted to a place where the risk of predation is higher than in non-restored habitats (Hawlena et al. 2010). Ecological traps are low-quality habitats for reproduction and survival, which cannot sustain a population, and yet are preferred over other alternative high-quality habitats (Donovan & Thompson III 2001). In Hale & Swearer's (2017) review, they point out the risk of creating ecological traps in restoration projects and emphasize that this possibility has been hardly explored in ecological restoration studies.

Cliff habitats are unique environments where cliff-nesting birds breed in holes, crevices or platforms. Mining activity generates cliff environments that attract cliff-nesting birds, many of which are protected species (Madroño et al. 2004; Lundholm & Richardson 2010). Cliff environments at mining sites (aggregate sites and quarries for aggregate and cement production) can exert an important attraction over some birds, such as the colonial Sand Martin *Riparia riparia*, up to the point that in some areas they accommodate their main colonies (De Lope et al. 1987; SCV 1999; González 2004; Heneberg 2007; SCV 2007).

To the best of our knowledge, there is little literature regarding the bird community that colonizes the mining sites (Castillo et al. 2008). Many of the conventional restoration actions that are carried out in mining sites do not benefit the cliff-nesting fauna that can colonize these areas, such as land filling quarries (Castillo et al. 2008).

We believe studies regarding the opportunities of carrying out actions to promote cliff habitats in mining sites are lacking, as well as projects with the aim of managing and promoting cliff-nesting species with conservation concern and which could enhance local biodiversity both during active and restoration stages of mining sites.

One of the cliff-nesting bird groups that is frequently found in mining sites are raptors. They can be key species that participate in top-down ecological processes that can have great influence on spatial distribution of prey species. In some cases, in the proximity of nests, raptors can exert a negative effect on prey density through direct and indirect effects on the prey (predation and perceived risk of predation, respectively) (Mönkkönen et al. 2007). In other cases, dominant raptors may benefit other species in the proximity of the nests, because the presence of a dominant raptor creates a predator-free space for the prey of smaller subordinate raptors (Byholm et al. 2012). Thus, dominant raptors can condition the spatial assembly of the communities of predators and prey (Mönkkönen et al. 2007).

Eagle Owls *Bubo bubo* are cliff-nesting nocturnal raptors that are distributed throughout the Iberian Peninsula (Penteriani & Delgado 2016) and they are frequently found in mining sites (Zuberogoitia et al. 1994; Marchesi et al. 2002; Dalbeck & Heg 2006). Though rabbits *Oryctolagus cuniculus* are their main prey, the Eagle Owl is considered to be a generalist top predator, having identified in its diet, aside of other smaller predators, more than 90 species of mammals, 170 birds, 10 reptiles, 9 amphibians, 30 fishes and 15 invertebrates (Penteriani & Delgado 2016). This implies that habitat improvement actions directed at the cliff-nesting birds at mining sites could incur in the risk of creating ecological traps due to excessive predation by the Eagle Owl.

Our general objective is to analyze whether the presence of top predators could limit the success

of habitat enhancement actions for cliff-nesting fauna in restoration projects. To carry out this objective we studied the presence and diet of Eagle Owls in mining sites in Spain, and analyzed what implications they could have for mining restoration and cliff-nesting bird management. Our hypothesis is that the Eagle Owl could be a relevant predator of the cliff-nesting birds that colonize mining sites and that the Eagle Owl's predation pressure could limit the abundance and density of cliff-nesting birds in the mining sites. We expect that the predation of the Eagle Owl on the cliff-nesting birds in mining sites will increase with the abundance of cliff-nesting birds and decrease with rabbit abundance. Taking into account our results, we discuss the effect of Eagle Owls on the cliff-nesting birds and the risk of creating ecological traps by an excess of predation in restoration projects for cliff-nesting birds.

METHODS

Study area

We studied 28 mining sites in 2016, which were representative of the center and East of the Iberian Peninsula (Fig. 3.1). The sites varied in size from four to 500 ha and the extracted materials were clay, granite, gypsum, limestone, porphyry, pozzolan, sand and gravel. Their elevation ranged from sea level to 1,100 m. The climate is Mediterranean, and the annual mean temperature and precipitation ranged between 10.2 and 18.1°C and between 318 to 675 mm, respectively.

Eagle Owl presence and diet

Surveys were carried out between May and July, during the breeding season (mid-December to mid-July, León-Ortega et al. 2017) to identify

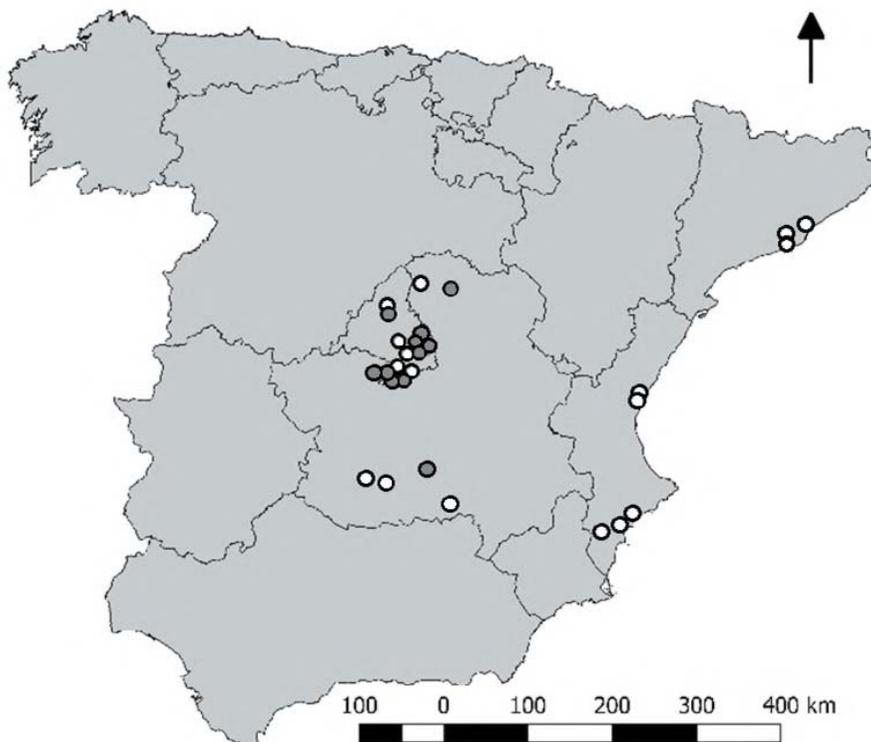

Fig. 3.1 Location of the 28 studied mining sites in 2016. Grey indicates the 11 mining sites where the diet of the Eagle Owl was studied.

signs of Eagle Owl presence (individuals, nests, roosting places, feathers and pellets) and to interview managers and workers regarding Eagle Owl presence at each mining site. The relative small size of the mining sites, the visual accessibility of the cliffs and the conspicuity of Eagle Owl signs facilitated the detection of the individuals. We found Eagle Owl pellets in 15 out of 28 mining sites, but a minimum of 20 pellets per mining site were only collected in 11 of them (Fig. 3.1). The pellets were located in habitual perches or roosting places of the species, such as large cavities in the cliffs. The content of the pellets was analyzed following the methodology of Martí et al. (2007). The prey remains were identified using specific bibliography (Dueñas Santero & Peris Álvarez 1985; Moreno 1986, 1987; García-Matarranz 2013) and skeleton collections of the prey species present in the study area. Identification was at species level, and for those cases where the identification was not possible, gender, family or order level was reached. The minimum number of specimens found in each pellet was estimated by the repetition of bones. We estimated the percentages at which the different taxonomic groups and the different species, including cliff-nesting birds and rabbits, appeared in the diet per mining site.

Abundance and richness of cliff-nesting birds

The abundance of all cliff-nesting bird species in the 28 mining sites was estimated through itineraries on foot which covered the mining sites completely (from 800 to 8000 m, according to their surface) and allowed visual inspection of the cliff environments. We counted all individuals detected by sight and sound, avoiding double counts when individuals were seen several times at the same location. Surveys were carried out during the first hours of the day and in favorable weather. Surveys lasted between two to four

hours, according to the surface of the mining site. We considered as cliff-nesting species those indicated to nest in cliffs, even if not exclusively, in the Atlas for reproductive birds of Spain (Martí & Moral 2003). The density of cliff-nesting birds in each mining site was estimated by dividing the total abundance of cliff-nesting birds by the area of the mining site.

Rabbit abundance in the mining sites

We used an indirect method to estimate the relative abundance of rabbits in the 28 mining sites. Thirty survey points were distributed on the entire accessible surface of the mining site at equidistant distances. The distance between survey points varied from 50 to 250 m according to the surface of the mining site. At each survey point we estimated the density of pellets in four quadrants of 1.5 × 1.5 m and the distance to the closest scraping, latrine and burrow in a 20 m radius (Fig. 3.2). With this information, eight

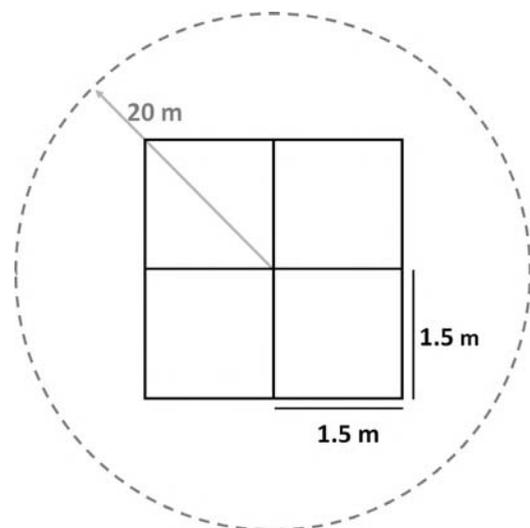

Fig. 3.2 Design of the survey points of rabbit activity. The four quadrants were used to estimate the density of rabbit pellets and the circle was used to measure the distance to the closest scraping, latrine and burrow. Image not in scale.

indicators of rabbit activity were calculated per mining site: average density of rabbit pellets, average minimum distance to the closest scratching, latrine and burrow, and proportion of survey points in which each of the four signs of activity were present.

Statistical analysis

To estimate the rabbit density, we performed a Principal Component Analysis (PCA) with the eight indicators of rabbit activity. The coordinates of the 28 mining sites in axis 1 were used as a *rabbit abundance index* in the mining sites.

Correlations (Pearson for variables with normal distribution and Spearman for not normally distributed variables) were performed between pairs of variables related with the diet, the abundance and density of cliff-nesting birds, and the rabbit abundance index. We compared the rabbit abundance index and cliff-nesting bird density between quarries with presence or absence of Eagle Owls with Mann-Whitney

U-tests. All tests were calculated with correlation cut-off r greater than 0.6 and significance cut-off p lower than 0.05, and using R 3.4.0 (R Core Team 2017).

RESULTS

Presence of Eagle Owl in mining sites

Eagle Owl presence was confirmed in 18 (64%) of the 28 mining sites (Table 3.1). Breeding was confirmed in seven of the sites (presence of chicks or laying females). One breeding pair was detected per mining site, except in the largest mining site (500 ha) which had 2 pairs, and a maximum of 3 chicks per nest. Pellets were found in 15 mining sites, though 20 or more pellets were found in 11 sites (39% of the sites), and therefore statistical analyses for the diet were performed only with the information of these 11 sites.

Table 3.1 Mining sites with presence of Eagle Owl, number of observed adults, confirmed breeding, presence of pellets, and mining sites where more than 20 pellets were found. Mining sites appear alphabetically.

Mining site	Observed adults	Breeding	Pellets	Pellets > 20
ALM	2	No	Yes	No
CTO	1	Yes	Yes	Yes
DOL	1	No	No	No
EBU	1	No	No	No
EMA	1	No	Yes	Yes
EMO	1	Yes	Yes	Yes
ESP	1	Yes	Yes	Yes
FON	0	No	Yes	No
LCH	1	Yes	Yes	Yes
LPO	1	No	Yes	Yes
LSO	0	Yes	Yes	Yes
MOS	1	Yes	Yes	Yes
OFR	1	No	No	No
OLI	1	No	Yes	Yes
SCA	0	No	Yes	No
TER	0	No	Yes	No
VIL	2	No	Yes	Yes
YEP	1	Yes	Yes	Yes
Total	16	7	15	11

Diet of the Eagle Owl in mining sites

In the 11 sites with > 20 pellets, a total of 432 pellets (mean \pm SE = 39 ± 4 per mining site) were analyzed (Table S3.1). A total of 732 minimum number of preys were identified, 66 ± 4 preys per mining site (Table S3.2). Of the total prey, 83% were mammals, 13% birds, 2% reptiles, 0.8% invertebrates and 0.5% amphibians. The percentage of mammals in the diet varied from 63% to 100% (83 ± 4), birds from 0 to 36% (13 ± 3), reptiles between 0 and 18% (2.4 ± 1.6), invertebrates between 0 and 4.2% (0.9 ± 0.4) and amphibians from 0 to 2.4% (0.4 ± 0.2) (Fig. 3.3). Rabbits were the main prey in the diet and their percentage varied from 14% to 84% (63 ± 6).

We identified a total of 17 species, and 5 genus (Table 3.2). Among the bird species in mining sites, five cliff-nesting species were identified. In order of abundance: *Columba* sp. (which includes Rock Doves *Columba livia* and Stock Doves *Columba oenas*), Western Jackdaws *Corvus*

monedula, Common Kestrels *Falco tinnunculus*, Starlings *Sturnus* sp. and Barn Owls *Tyto alba*. The percentage of cliff-nesting birds in the diet varied from 0 to 27% (6 ± 3 per mining site).

Neither the percentage of birds in the diet ($r = -0.37$, $S = 302.19$, $p = 0.26$), nor the percentage of cliff-nesting birds in the diet ($r = -0.05$, $S = 230.19$, $p = 0.89$) were related to the percentage rabbits in the diet.

Cliff-nesting bird abundance and richness in mining sites

The total abundance of cliff-nesting birds in the 28 mining sites was of 5166 individuals, varying between 25 and 687 individuals (185 ± 34) per mining site (Fig. 3.4). There were more than 100 cliff-nesting individuals in 57% of the mining sites. A total of 24 cliff-nesting species were observed, and the richness varied from 3 to 17 species (9 ± 1) per mining site. At least 50% of the species were present in 60% of the sites (Fig. 3.4). The most abundant (> 300 individuals) were Rock Sparrows *Petronia petronia* ($n = 930$), Sand Martins *Riparia riparia* ($n = 908$), Western

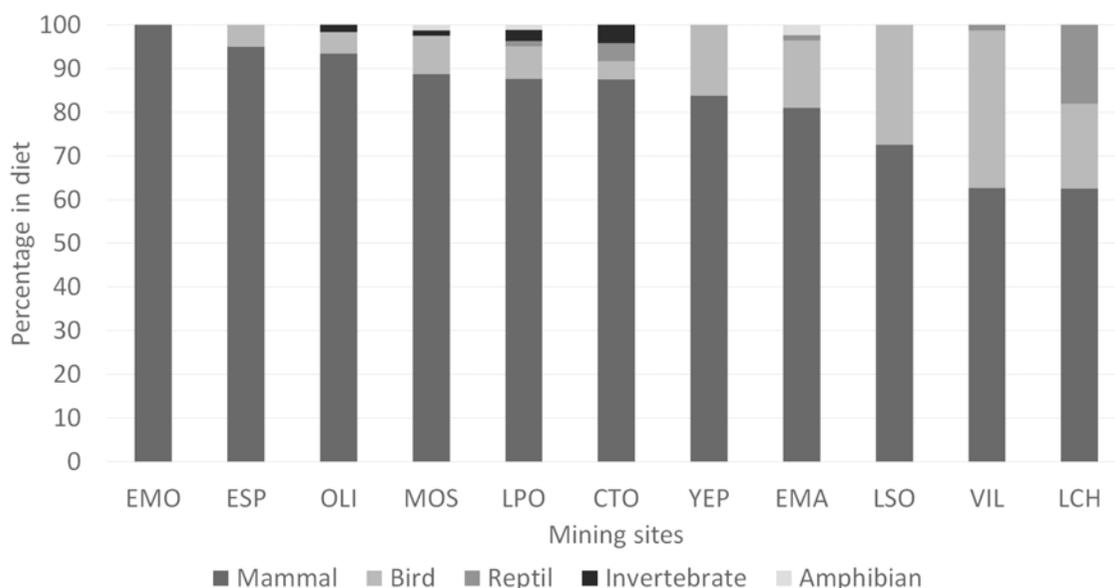

Fig. 3.3 Percentage of each taxonomic group in the Eagle Owl's diet in the 11 mining sites where more than 20 pellets were found. Mining sites are ordered in descending percentage of mammal prey.

Table 3.2 Minimum number of prey for each species found in the pellets and the percentage it represents in the Eagle Owl's diet, ordered by taxa and in descending order.

Group	Species	Minimum number of preys in diet	% in diet
Mammal	<i>Oryctolagus cuniculus</i>	448	61
	<i>Apodemus sylvaticus</i>	70	10
	<i>Rattus</i> sp.	38	5
	<i>Microtus duodecimcostatus</i>	24	3
	<i>Mus</i> sp.	7	1
	<i>Mus spretus</i>	7	1
	<i>Arvicola sapidus</i>	4	1
	Undetermined micromammal	3	0
	Undetermined mammal	2	0
	<i>Erinaceus europaeus</i>	1	0
	<i>Lepus granatensis</i>	1	0
	Undetermined lagomorph	1	0
Bird	Undetermined bird	28	4
	<i>Sturnus</i> sp.	22	3
	<i>Columba</i> sp.	16	2
	<i>Columba palumbus</i>	6	1
	<i>Pica pica</i>	5	1
	Undetermined corvid	4	1
	<i>Corvus monedula</i>	4	1
	Undetermined fringillidae	3	0
	Undetermined passeriformes	3	0
	<i>Alectoris rufa</i>	2	0
	<i>Falco tinnunculus</i>	1	0
	<i>Fulica atra</i>	1	0
	Undetermined raptor	1	0
	<i>Turdus philomelos</i>	1	0
	<i>Tyto alba</i>	1	0
Reptile	Undetermined reptile	13	2
	<i>Timon lepidus</i>	3	0
	Undetermined ophidian	1	0
Amphibian	Undetermined amphibian	2	0
	<i>Bufo</i> sp.	2	0
	<i>Pelobates cultripes</i>	1	0
Invertebrate	Undetermined invertebrate	6	1

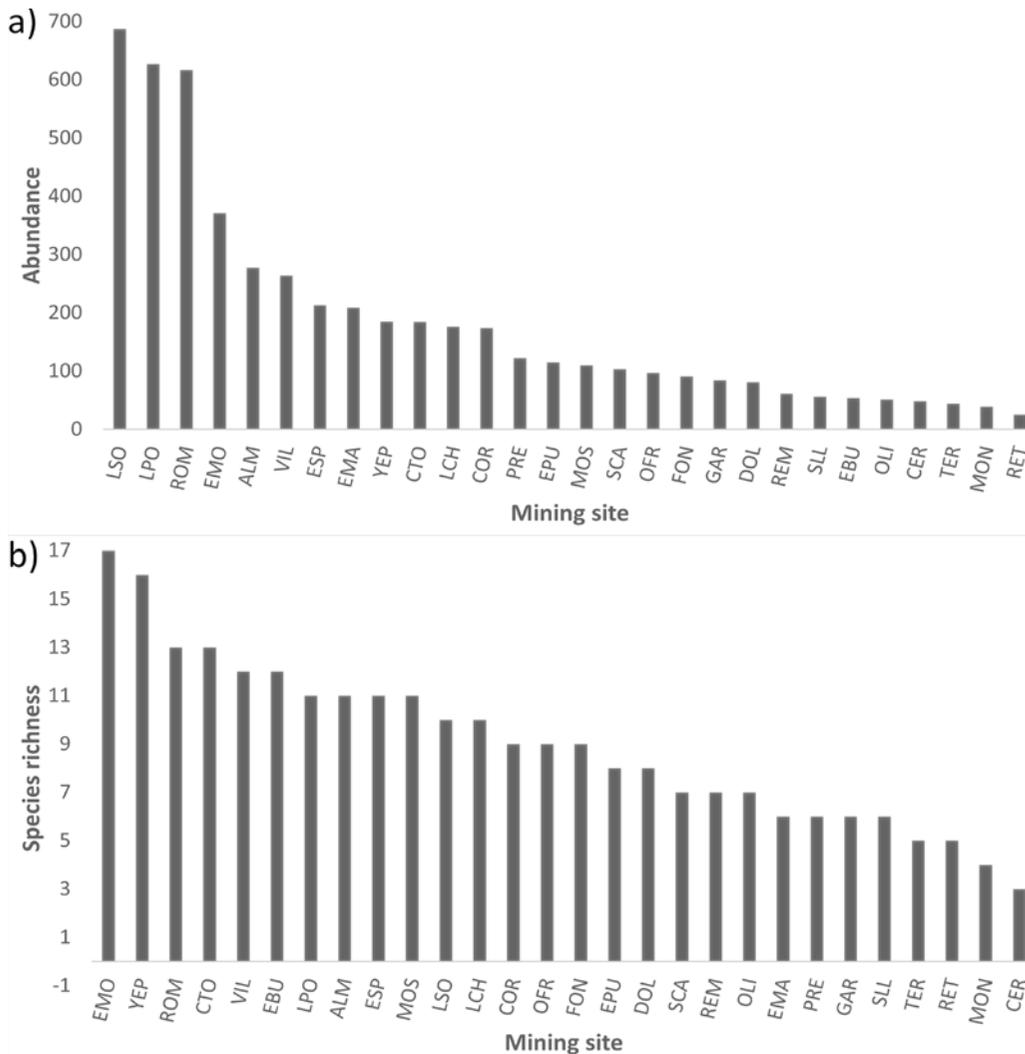

Fig. 3.4 a) Abundance and b) richness of cliff-nesting birds in the 28 mining sites.

Jackdaws ($n = 847$), House Sparrows *Passer domesticus* ($n = 532$), Spotless Starlings *Sturnus unicolor* ($n = 433$), Rock Doves ($n = 423$), and Common Swifts *Apus apus* ($n = 314$).

The cliff-nesting bird abundance in mining sites with and without Eagle Owls (18 with presence and 10 without) was not significantly different ($n = 28$, $W = 50.5$, $p = 0.065$), though the mean abundance was higher in presence of Eagle Owl. The cliff-nesting bird density differed between mining sites regarding Eagle Owl presence ($n = 28$, $W = 40.5$, $p = 0.019$), with more bird density occurring in mining sites where the Eagle Owl

was present.

There were no relationships between the abundance of cliff-nesting birds in the mining sites and the percentage of birds in the diet ($n = 11$, $r = 0.14$, $S = 189.86$, $p = 0.688$) or the percentage of cliff-nesting birds in the diet ($n = 11$, $r = 0.52$, $S = 106.67$, $p = 0.105$). There were also no relationships between the density of cliff-nesting birds in the mining sites and the percentage of birds in the diet ($n = 11$, $r = -0.35$, $t = -1.12$, $p = 0.292$) or the percentage of cliff-nesting birds in the diet ($n = 11$, $r = -0.33$, $S = 293.35$, $p = 0.316$).

The analysis of the most abundant cliff-nesting species that appeared in the diet (*Sturnus sp.* and *Columba sp.*, which included both *Columba livia* and *Columba oenas*), indicated that the percentage of birds in the diet was not related with the abundance of *Columba sp.* ($n = 11, r = 0.53, S = 103.68, p = 0.09$) or *Sturnus sp.* ($n = 11, r = 0.36, t = 1.15, p = 0.28$) in the mining sites. Also, the percentage of cliff-nesting birds in the diet was also not related to the abundance of *Columba sp.* ($n = 11, r = 0.33, S = 148.03, p = 0.33$) or *Sturnus sp.* ($n = 11, r = 0.16, S = 185.29, p = 0.64$) in the mining sites.

Rabbit abundance in the mining sites

There was rabbit activity (rabbit pellets, latrines, burrows or scratches) in 25 (89%) of the 28 mining sites (Table S3.3). The PCA showed a descending gradient of rabbit activity (from left to right in Fig. 3.5). The PCA1 absorbed 87% of the variance, and therefore we considered it as a *rabbit abundance index* in the analyses. The 8 analyzed parameters correlated highly with each other and with PCA1 (Table S3.4).

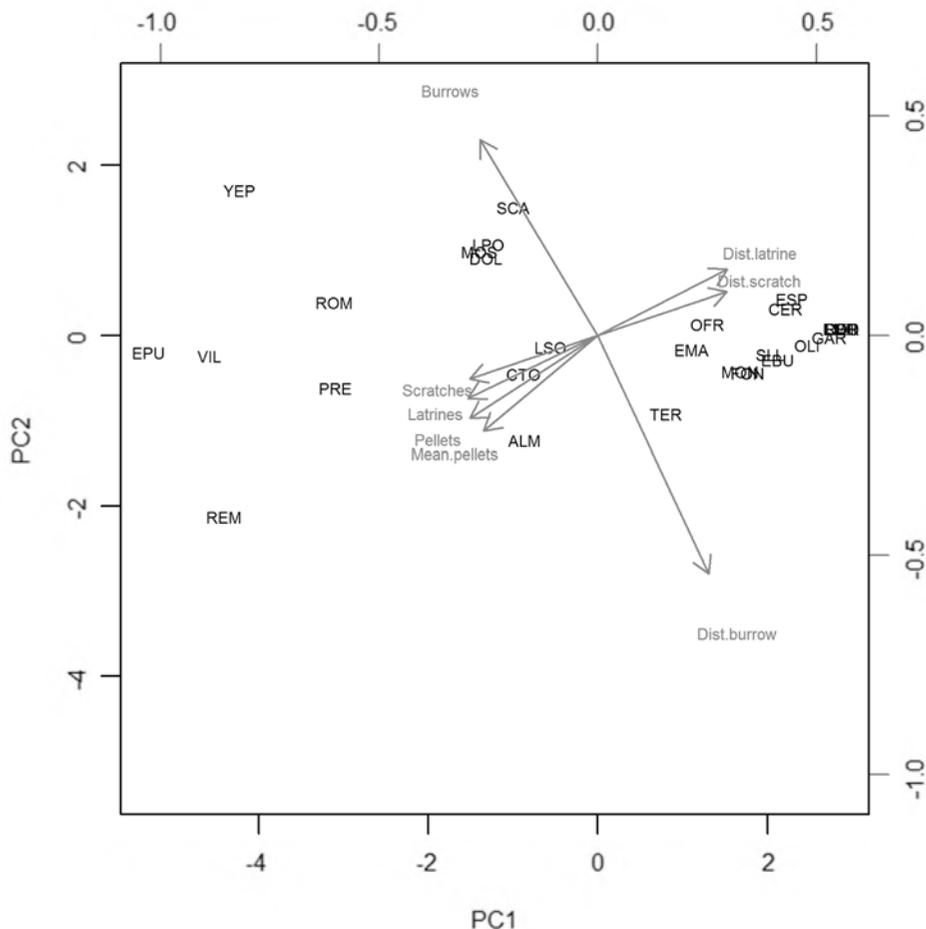

Fig. 3.5 Biplot of the mining sites and the parameters of rabbit activity, obtained from the axis 1 and 2 of the PCA. Abbreviations: Dist.latrine: average minimum distance to the closest latrine (m), Dist.scratch: average minimum distance to the closest scratching (m), Dist.burrow: average minimum distance to the closest burrow (m), Mean.pellets: average density of rabbit pellets, Burrow: % survey points with burrows, Pellets: % survey points with pellets, Latrines: % survey points with latrines, Scratches: % survey points with scratches. Mining sites are distributed according to a decreasing rabbit abundance gradient, from left to right.

There was neither a relationship between the rabbit abundance index and the percentage of rabbits in the diet ($n = 11, r = -0.32, S = 292.16, p = 0.325$), the percentage of birds in the diet ($n = 11, r = -0.54, t = -1.94, p = 0.084$) or the percentage of cliff-nesting birds in the diet ($n = 11, r = -0.58, S = 346.61, p = 0.064$). The rabbit abundance index was not related with the presence (18 mining sites) and absence (10 mining sites) of Eagle Owls in the mining sites ($W = 94, p = 0.867$).

DISCUSSION

The possible consequences of the presence of top predators for the success of restoration actions for animals is still poorly understood. This work contributes with novel data about the risks of the presence of a top predator, the Eagle Owl, in mining sites. Our main objective was to analyze whether when carrying out actions to improve cliff habitats for cliff-nesting birds in mining sites there could be a risk of creating habitats with an excess of predation. Based on our results, we conclude that the Eagle Owl does not seem to exert neither a significant direct or indirect pressure on the cliff-nesting birds, even on wild pigeons which were the most abundant cliff-nesting species in its diet. Therefore, restoration projects with habitat improvement actions for cliff-nesting birds in Spain would not entail a significant risk of generating ecological traps by excess of Eagle Owl predation for these species. Furthermore, restoration plans could consider favoring the presence of the Eagle Owl, a threatened species in other areas in Europe (SPEC3 category).

Presence of Eagle Owl in mining sites

The Eagle Owl, a top predator with Palearctic distribution and able to prey on a wide range of species including other predators (Penteriani

& Delgado 2016), appeared at the mining sites in Spain frequently. Though the presence of this species has been related to areas with low human influence (Cramp 1988), other authors confirm the colonization and reproduction of the Eagle Owl in areas with human activity, such as cultivated, urbanized or mined areas (Zuberogoitia et al. 1994; Marchesi et al. 2002; Dalbeck & Heg 2006). Our findings confirm that Eagle Owls breed successfully in mining sites and that mining sites probably offer cliffs with features that are similar to the natural cliffs where this species reproduces in Mediterranean areas (Martínez & Calvo 2000). The high percentage of colonization found in this study confirms the capacity of the Eagle Owl to colonize mining sites, and therefore, restoration plans should consider the effect of the direct and indirect pressure that this top predator could exercise over cliff-nesting birds, and thus limit their colonization in restored mining sites.

Diet of the Eagle Owl in mining sites

The Eagle Owl's diet in this study was based mainly on mammals, with rabbits as its main prey. These results coincide with other diet studies in the Iberian Peninsula carried out in non-mining sites (Jaksić & Marti 1984; Donázar et al. 1989; Martínez & Zuberogoitia 2001; Antón et al. 2008; Tobajas et al. 2016; Zarco et al. 2016) (Table S3.5). The proportion of birds and cliff-nesting birds in the diet was relatively low, and the proportion of the rest of taxa was very low, which also confirms what has been described in other studies (Perez Mellado 1978; Tobajas et al. 2016; Zarco et al. 2016). Our results suggest that the composition of the Eagle Owl's diet in mining sites is similar to its diet in other Mediterranean habitats. The low percentage of birds in the diet suggests that the Eagle Owl does not exercise a high predation on the birds at the mining sites in general, and specifically on cliff-nesting species.

The density of cliff-nesting birds was higher in mining sites with presence of Eagle Owl than in mining sites with absence of this top predator. The colonization of mining sites by the Eagle Owl and promoting its presence through restoration actions does not appear to imply an important risk of creating ecological traps for cliff-nesting birds through predation excess by this top predator.

Cliff-nesting bird abundance and richness in mining sites

The abundance, density and species richness of cliff-nesting birds in the mining sites was high, indicating that cliff environments of the mining sites were easily colonized by these bird species, some of them with conservation concern. This suggests that actions to promote habitat enhancement for cliff-nesting birds could be an interesting alternative in mining restoration.

The cliff-nesting bird abundance in mining sites did not differ with and without Eagle Owl presence, and the density of cliff-nesting birds was higher in mining sites with Eagle Owl presence. This could indicate that the presence of Eagle Owls does not limit the cliff-nesting bird community in the mining sites. This species is a known super-predator that predated smaller raptors (Lourenço et al. 2011) such as we confirmed in the present study for Common Kestrels and Barn Owls. This pressure on smaller raptors might generate predator-free areas that promote a higher abundance and density of their prey species in the mining sites. In that sense, the higher density of cliff-nesting birds found in mining sites with presence of Eagle Owl probably deserves additional research to determine whether the Eagle Owls generate predator-free areas for the main prey of other smaller predators.

Our results indicate that pigeons and starlings are the most abundant birds in the diet of the

Eagle Owl in the mining sites. Other authors describe that when rabbit abundance decreases, Eagle Owls could feed more frequently on birds with a similar size to the rabbit (Perez Mellado 1978; Tobajas et al. 2016) and describe high proportions of pigeons in the Eagle Owl's diet in such circumstances (Perez Mellado 1978; Penteriani & Delgado 2016; Tobajas et al. 2016; Zarco et al. 2016). The cliff habitats in the mining sites, which provide adequate nesting places for wild pigeons, and their frequent proximity to agricultural areas, which provide them with feeding areas, could favor high populations of wild pigeons in some mining sites. Cliff habitats at the mining sites could be the most extensive and accessible ones for wild pigeons in some rural areas. Because pigeons and starlings are common species without relevant threats, promoting the presence of these cliff-nesting species as prey for the Eagle Owl in the mining sites could be recommended.

Rabbit abundance in mining sites

There was an elevated presence of rabbits in the mining sites, which was initially not expected as mining sites are industrially active places. Nonetheless, Mediterranean areas in Spain are known for an elevated abundance of rabbits. Furthermore, mining sites normally limit the access to hunters, and they are frequently fenced due to security reasons, which contributes to reduce human persecution.

Though rabbits were the main prey of the Eagle Owls, the proportion of rabbits in the diet was not related with the rabbit abundance in the mining sites. Furthermore, the abundance of rabbits in the mining sites was not related to Eagle Owl presence. These results suggest that Eagles Owls capture the rabbits also in the habitats around the mining sites. The size of the home ranges of the breeding males (123 ± 125 ha, Penteriani et al. 2008 cited in Penteriani and Delgado 2016), the main provider of prey to females and chicks,

was larger than the mean size of the studied mining sites (59 ± 19 ha). Consistent with this statement, the rabbit abundance in mining sites was not related to the percentage of birds in the diet. These results suggest that the size of the restoration areas respect to the size of the home range of the top predators could be an important factor influencing the final effect of top predators in the success of restoration projects for fauna, because the abundance of prey outside the restored areas will condition the amount of captures in the restored sites.

The highest density of rabbits in the Mediterranean areas of Spain is observed in mosaic landscapes with herbaceous crops and pastures that supply food, remnants of natural woody vegetation that provide shelter, and located on substrates where rabbits can excavate burrows easily (Beltran 1991; Moreno & Villafuerte 1995; Rueda et al. 2008; Santilli & Bagliacca 2010; Gálvez-Bravo 2011; Narce et al. 2012; Dellafiore et al. 2014). In parts of the unrestored mining sites the substrate could be propitious for burrowing, but the lack of crops and grasslands to provide food, and woody vegetation to provide refuge, could limit rabbit populations and could also explain why the Eagle Owls hunt in the surroundings of the mining sites. These results suggest that to manage Eagle Owls in the mining sites it is important to consider the introduction of feeding and refuge habitats for rabbits in the restorations, and to consider including the management of the areas surrounding the mining since they probably provide the main source of prey. The edge of the mining sites, in contact with these exterior habitats, should be specially considered to promote rabbits.

Implications for restoration and management for cliff-nesting birds

We found an important community of cliff-nesting birds colonizing the mining sites, some of

which with conservation concern. This stresses the need for managing these species during the active phases of the mining sites and suggests that actions to promote habitat enhancement for cliff-nesting birds could be an interesting alternative in mining restoration.

One of the cliff-nesting birds that colonizes most of the mining sites in the study area is the Eagle Owl, a generalist top predator. However, the low proportion of birds and cliff-nesting birds in the Eagle Owl's diet in the mining sites and the abundance of cliff-nesting birds in presence of this owl suggest that is not an important limitation for cliff-nesting bird colonization of the mining sites.

Rabbits were the Eagle Owl's main prey. Therefore, promoting rabbits in the mining sites and their surroundings could help prevent an excess of predation on cliff-nesting birds, if restoration and management actions for cliff-nesting birds were implemented during the active or restoration phases of the mining sites.

ACKNOWLEDGMENTS

This project was financed through a partnership between LafargeHolcim Spain, the International Foundation for the Restoration of Ecosystems (FIRE) and the University of Alcalá (FORECO research group). NM was supported by a predoctoral grant funded by the University of Alcalá. Special acknowledgments to Pilar Gegúndez, Raúl Pérez and José María Rey Benayas. Finally, special thanks to Javier Garrido for his help during the field work.

REFERENCES

- Antón, M. G., Pérez-García, J. M., Botella, F., & Sánchez-Zapata, J. A. 2008. Dieta del Buho real (*Bubo Bubo*) en el Sur de la provincia de Alicante. In *Actas Cuarto Congreso de la Naturaleza de la región de Murcia y I Sureste Ibérico*

- Arthur, A. D., Henry, S., & Reid, A. 2010. Influence of revegetation on predation rates by introduced red foxes (*Vulpes vulpes*) in south-eastern Australian farmland. *Austral Ecology* **35**: 919–928.
- Beltran JF (1991) Temporal abundance pattern of the wild rabbit in Doñana, SW Spain. *Mammalia* **55**:591–599
- Byholm P, Burgas D, Virtanen T, Valkama J (2012) Competitive exclusion within the predator community influences the distribution of a threatened prey species. *Ecology* **93**:1802–1808
- Castillo I, Elorriaga J, Zuberogoitia I, Azkona A, Hidalgo S, Astorkia L, Iraeta A, Ruiz F (2008) Importancia de las canteras sobre las aves rupícolas y problemas derivados de su gestión. *Ardeola* **55**:103–110
- Cramp S (1988) *Handbook of the birds of Europe, the Middle East and North Africa. The birds of the Western Palearctic*. Oxford University Press, Oxford, United Kingdom
- Dalbeck L, Heg D (2006) Reproductive success of a reintroduced population of Eagle Owls *Bubo bubo* in relation to habitat characteristics in the Eifel, Germany. *Ardea* **94**:3–21
- Dellafore CM, Rouco C, Vallés SM, Fernández JBG (2014) Seasonal habitat use by the European rabbit (*Oryctolagus cuniculus*) in a coastal dune system in SW Spain. *Animal Biodiversity and Conservation* **37**:233–242
- Donázar JA, Hiraldo F, Delibes M, Estrella RR (1989) Comparative food habits of the Eagle Owl *Bubo bubo* and the Great Horned Owl *Bubo virginianus* in six Palearctic and Nearctic biomes. *Ornis Scandinavica* **20**:298–306
- Donovan TM, Thompson III FR (2001) Modeling the ecological trap hypothesis: a habitat and demographic analysis for migrant songbirds. *Ecological Applications* **11**:871–882
- Dueñas Santero ME, Peris Álvarez SJ (1985) *Clave para los micromamíferos (insectívora y rodentia) del Centro y Sur de la Península Ibérica. Claves para la Identificación de la Fauna Española*, 27. Dep. Zool. De la Fac. de Biología de la Universidad de Salamanca, Salamanca
- Gálvez-Bravo L (2011) Conejo – *Oryctolagus cuniculus*. In: Salvador A, Cassinello J (eds) *Enciclopedia Virtual de los Vertebrados Españoles*. Museo Nacional de Ciencias Naturales, Madrid.
- García-Matarranz V (2013) *Guía de Identificación de Rapaces Ibéricas por Restos Óseos*. Gobierno de España, Ministerio de Agricultura, Alimentación y Medio Ambiente, Madrid
- González JL (2004) El avión zapador (*Riparia riparia*) en Extremadura. Problemática y propuestas de conservación. In: *Congreso sobre especies protegidas en Extremadura*. Trujillo.
- Hale R, Swearer SE (2017) When good animals love bad restored habitats: How maladaptive habitat selection can constrain restoration. *Journal of Applied Ecology* **54**:1478–1486
- Hawlena D et al. (2010) Ecological trap for desert lizards caused by anthropogenic changes in habitat structure that favor predator activity. *Conservation Biology* **24**:803–809
- Heneberg P (2007) Sand martin (*Riparia riparia*) in the Czech Republic at the turn of the millenium. *Linzer Biologische Beiträge* **39**:293–312
- Jaksić FM, Marti CD (1984) Comparative food habits of Bubo Owls in Mediterranean-type ecosystems. *The Condor* **86**:288–296
- León-Ortega M et al. (2017) Factors influencing territorial occupancy and reproductive success in a Eurasian Eagle-owl (*Bubo bubo*) population. *PLoS ONE* **12**:1–15
- De Lope F, Fernández A, De La Cruz C (1987) La situación del avión zapador (*Riparia riparia*) en Extremadura. *Alytes* **5**:121–132
- Lourenço R et al. (2011) Superpredation patterns in four large European raptors. *Population Ecology* **53**:175–185
- Lundholm JT, Richardson PJ (2010) Habitat analogues for reconciliation ecology in urban and industrial environments. *Journal of Applied Ecology* **47**:966–975
- Madroño A, González C, Atienza J (2004) *Libro Rojo de las Aves de España*. Dirección General para la Biodiversidad, SEO/BirdLife, Madrid
- Marchesi L, Sergio F, Pedrini P (2002) Costs and benefits of breeding in human-altered landscapes for the Eagle Owl *Bubo bubo*. *Ibis* **144**:E164–E177
- Martí CD, Bechard M, Jaksic FM (2007) Food Habits. Pages 129–152. In: Bird DM, Bildstein K (eds) *Raptor Research and Management Techniques*. Hancock House Publishers, Surrey BC
- Martí R, Moral J (2003) *Atlas de las aves reproductoras de España*. Dirección General de Conservación de la Naturaleza-SEO, Madrid
- Martínez JA, Zuberogoitia I (2001) The response of the

- Eagle Owl (*Bubo bubo*) to an outbreak of the rabbit haemorrhagic disease. *Journal for Ornithologie* **211**:204–211
- Martínez JE, Calvo JF (2000) Selección de hábitat de nidificación por el búho real *Bubo bubo* en ambientes mediterráneos semiáridos. *Ardeola* **47**:215–220
- Mönkkönen M, Husby M, Tornberg R, Helle P, Thomson RL (2007) Predation as a landscape effect: The trading off by prey species between predation risks and protection benefits. *Journal of Animal Ecology* **76**:619–629
- Moreno E (1986) Clave osteológica para la identificación de los passeriformes ibérico. *Ardeola* **33**:69–129
- Moreno E (1987) Clave osteológica para la identificación de los passeriformes ibéricos. *Ardeola* **34**:249–273
- Moreno S, Villafuerte R (1995) Traditional management of scrubland for the conservation of rabbits *Oryctolagus cuniculus* and their predators in Doñana National Park, Spain. *Biological Conservation* **73**:81–85
- Narce M, Meloni R, Beroud T, Pléney A, Ricci JC (2012) Landscape ecology and wild rabbit (*Oryctolagus cuniculus*) habitat modeling in the Mediterranean region. *Animal Biodiversity and Conservation* **35**:277–284
- Penteriani V, Delgado MM (2016) Búho real – *Bubo bubo*. In: Salvador A, Morales MB (eds). *Enciclopedia Virtual de los Vertebrados Españoles*. Museo Nacional de Ciencias Naturales, Madrid.
- Perez Mellado V (1978) Alimentación del Buho real (*Bubo bubo* L.) en España central. *Ardeola* **25**:93–112
- R Core Team (2017) R: A language and environment for statistical computing. R Foundation for Statistical Computing, Vienna
- Rueda M, Rebollo S, Gálvez-Bravo L, Escudero A (2008) Habitat use by large and small herbivores in a fluctuating Mediterranean ecosystem: Implications of seasonal changes. *Journal of Arid Environments* **72**:1698–1708
- Santilli F, Bagliacca M (2010) Habitat use by the European wild rabbit (*Oryctolagus Cuniculus*) in a coastal sandy dune ecosystem of central Italy. *Hystrix the Italian Journal of Mammalogy* **21**:57–64
- Sociedad para la Conservación de los Vertebrados (SCV) (1999) Situación actual del avión zapador (*Riparia riparia*) en la comunidad de Madrid. Pages 72–77. In: SEO-Monticola (eds), *Anuario Ornitológico de Madrid*. Madrid.
- Sociedad para la Conservación de los Vertebrados (SCV) (2007) *Censo de avión zapador (Riparia riparia) en la Comunidad de Madrid (2007)*. Madrid. <https://scv-conservacion.webcindario.com/avionzapador/zapador2007.html> (accessed 1 August 2018)
- Tobajas J, Fernandez-de-Simon J, Díaz-Ruiz F, Villafuerte R, Ferreras P (2016) Functional responses to changes in rabbit abundance: is the eagle owl a generalist or a specialist predator? *European Journal of Wildlife Research* **62**:85–92
- Zarco V, Talabante C, Viejo J (2016) Importancia de las aves rapaces en la dieta del búho real (*Bubo bubo* L., 1758) en el centro de la península Ibérica. *Boletín de la Real Sociedad Española de Historia Natural Sección Biología* **110**:15–21
- Zuberogoitia I, Campos LF, Crespo T, Ocio G (1994) Situación y datos sobre la reproducción de las rapaces nocturnas en Bizkaia. Pages 297–305. In: *Actas de las XII Jornadas Ornitológicas Españolas*. Almerimar (El Ejido-Almería)





CHAPTER IV

Restoration and management for cliff-nesting birds in
Mediterranean mining sites: The Sand Martin case study

CHAPTER IV

Restoration and management for cliff-nesting birds in Mediterranean mining sites: The Sand Martin case study

Rohrer, Z.¹, Rebollo, S.¹, Andivia, E.², Franco, J., Rodríguez Urquía, C.

¹Forest Ecology and Restoration Group, Departamento de Ciencias, Universidad de Alcalá, Madrid, Spain.

²Departamento de Biodiversidad, Ecología y Evolución, Universidad Complutense de Madrid, Madrid, Spain.

ABSTRACT

Enhancing habitats for threatened birds is one of the main targets in mining restoration. Cliff-nesting bird species often colonize anthropogenic environments such as mining sites (aggregate sites and quarries for aggregate and cement production). Mining activity can compromise breeding success, causing them to depend critically on the management and restoration of these sites. Our objective is to assess how to promote the conservation of Sand Martins (*Riparia riparia*) in mining sites and reconcile mining activity with their breeding in Mediterranean areas. We studied Sand Martin breeding habitat preferences in the mining sites at three spatial scales by comparing used and non-used sites and comparing the number of burrows and breeding pairs. At the mining site scale (29 mining sites and their corresponding surroundings in a 1 km buffer from the perimeter of the site; Sand Martins colonized 10 sites), they preferred areas with more surface of water, shorter distances to running water, older mining sites and sites dedicated to aggregate production. At the colony scale (vertical structures where the colonies were located), preference was affected by the orientation of the colony and the type of structure (stockpile or vertical extraction face). At the burrow scale (availability vs. use of the vertical surface of the colonies), burrows were concentrated in the most vertical areas of the face. Our results support restoration and management practices for Sand Martins in mining sites. We demonstrate that simple interventions at mining sites, like maintaining sandy vertical extraction faces, can enhance habitat quality and biodiversity conservation.

Key words: aggregate sector, bank swallow, best practice, habitat preference, guidelines, *Riparia riparia*.

Implications for Practice

- Monitoring a protected cliff-nesting burrowing bird which breeds at mining sites is an effective tool for studying the relevance of mining sites as breeding habitats for cliff-nesting species and to help establish management recommendations for them.
- The aggregate sector has more potential than the cement sector to help the mining industry to be more compatible with biodiversity conservation of cliff-nesting burrowing birds that use sandy substrates for nesting.
- Future research to assess reproductive success of the birds that colonize mining environments is necessary to understand the effect of these new habitats on the local populations.

INTRODUCTION

Aggregate production is a globally important industry. However, mining causes strong impacts on geomorphology, soil, vegetation and fauna, and restoring mining sites to their original ecosystem is not always possible (Bullock et al. 2011). Habitat enhancement is a restoration alternative to returning the area to the original ecosystem, which includes the creation of ecosystems different from those that existed before (Bradshaw 2000). This can allow the restoration of some attributes of the former ecosystem and new ecosystem services, even to the point of increasing the ecological value of an area (Bradshaw 1996), in terms of e.g. abundance of species of conservation concern. Many habitat enhancement experiences have been developed to obtain agricultural, forestry, leisure, and biodiversity conservation areas (McRae 1986). Well-managed quarries and gravel pits can support numerous species of fauna and flora, even when the mining sites are active (Yundt & Lowe 2002).

To the best of our knowledge, habitat enhancement for cliff-nesting species (both burrowing and not burrowing species) has been barely developed in scientific literature. Cliff-nesting birds colonize rocky habitats (vertical extraction faces, stockpiles, etc.) generated in mining sites (aggregate sites and quarries for aggregate and cement production), and there are authors who consider that some of these anthropogenic ecosystems could act as artificial analogues of natural ecosystems (Lundholm & Richardson 2010) serving as habitats for protected species (Castillo et al. 2008). However, site management frequently overlooks its potential to accommodate these species. The result is that restoration measures frequently act to the detriment of the cliff-nesting birds which colonized these rocky habitats (Castillo et al. 2008). Maintaining some of them could promote local biodiversity, decrease costs of restoration

projects by reducing movements of material to extend slopes, and avoid environmental risks associated with active restoration techniques, such as the appearance of alien species (Nentwig 2007). We propose to explore the habitat enhancement of these cliff habitats, as an innovative mining site restoration initiative.

The attraction effect that mining sites (both aggregate pits and quarries) exert on the cliff-nesting birds could be displacing them from their natural habitats. This effect, together with the mining activity itself, could affect the breeding success and viability of their populations. This stresses the need to develop specific management guidelines for cliff-nesting and cliff-nesting burrowing species in mining sites, as well as to include habitat enhancement actions in mining restoration plans. To effectively restore and manage cliff habitats, it is necessary to understand the habitat preferences of the cliff-nesting species at different scales in the mining sites.

Here, we used the Sand Martin (*Riparia riparia*) as our study species to analyze the importance of mining sites as breeding habitats for cliff-nesting burrowing birds, and to establish management and restoration recommendations (Appendix S4.1) that reconcile their conservation with mining activity. The Sand Martin's natural nesting habitats are sandy banks of rivers, streams and lakes (Cramp 1988), but in recent decades it has been increasingly nesting in man-made structures (Etxezarreta 2010), particularly nesting in mining sites (Jones 1987), to the point that natural colonies in some places in Europe seem to be becoming rare (De Lope et al. 1987; SCV 1999; González 2004; Heneberg 2007; SCV 2007). Though mining sites seem to be critical nesting areas, and their management could be crucial for this species (Ruiz de Aza et al. 2003), their relevance for accommodating this species is largely unknown (Burke 2017). The Sand Martins' increasing presence in mining sites

as breeding habitats highlights the importance of implementing measures to reconcile the conservation of cliff-nesting burrowing species with economic activities, in order to avoid turning mining sites into ecological traps. Trap habitats are low-quality habitats for reproduction and survival, which cannot sustain a population, and yet are preferred over other alternative high-quality habitats (Donovan & Thompson III 2001).

We expect that Sand Martins could be influenced by different variables at different spatial scales (mining site, colony and burrow scales) (Figure 4.1). We expect that they will favor mining sites located nearer to their natural habitats (Garrison et al. 1987, Waugh 1979) and near habitats with high insect production, such as open grassfields or water bodies (Hjertaas 1984, Garrison et al. 1987); we also expect they will be influenced positively by the availability of adequate nesting substrates, which will occur mostly in aggregate pits where there is a constant supply of fresh vertical faces of adequate grain (Lind et al. 2002; Szabó & Szép 2010; Heneberg 2013; Smalley et al. 2013) and by previous presence of Sand Martins (Szabó & Szép 2010); finally, we expect that they will select structures with larger vertical

surfaces and with less talus (fallen material at the base of the structure) (Burke 2017), and that their burrows will be located preferably at steeper slopes (Ye et al. 2016) (Table 4.1).

MATERIALS AND METHODS

Study area

This study was conducted in 2016 and 2017 in 29 mining sites belonging to cement and aggregate industries, in East and central Spain (Figure 4.2). The aggregate industry produces aggregates both at aggregate pits (by “scraping” the material directly from sandy extraction faces) and aggregate quarries (by blasting rock and then grinding it). This material is stored in outdoor stockpiles. Opposed to this is the cement industry, which does not store extracted material outdoors, and processes it indoors in cement plants instead.

The studied mining sites were characteristic of the study area and covered as much geographical surface as possible and included the largest possible range of conditions, including mining surface, activity, type of extracted material, age,

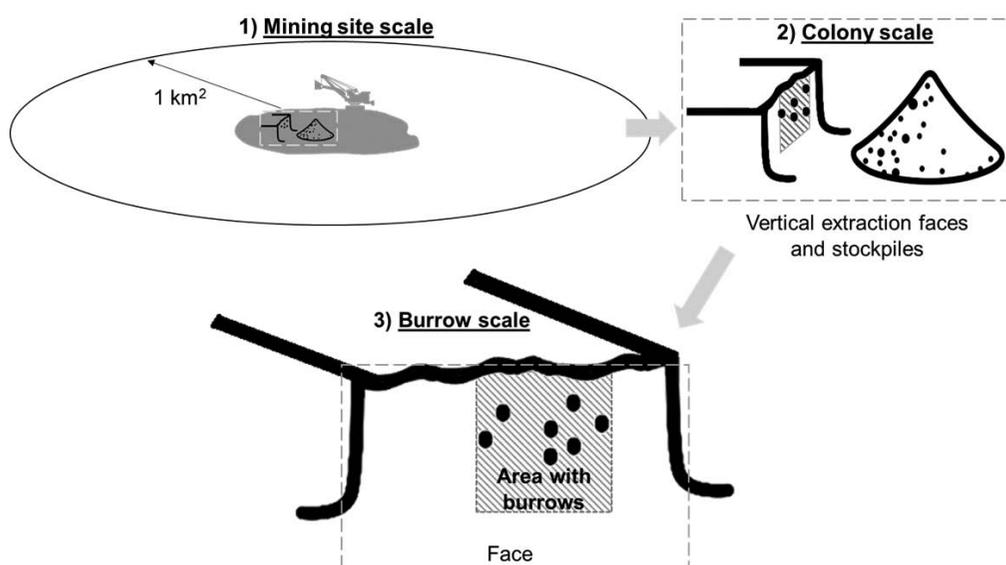

Figure 4.1 Scales of analysis of Sand Martin breeding habitat preferences. Images not in scale.

etc. (Table 4.1). Their elevation ranged from sea level to 1,100 m. The climate is Mediterranean, and the annual mean temperature and precipitation ranged between 10.2 and 18.1°C and between 318 to 675 mm, respectively and there was a gradient from the center (colder) to the East (warmer). The extracted materials were clay, granite, gypsum, limestone, porphyry, pozzolan, sand and gravel. The sites varied in their mining activity, being active, occasionally active or completely inactive. Sites varied in size from 4 to 500 ha.

Study species

Sand Martins are riparian cliff-nesting burrowing birds that excavate burrows in sandy vertical banks. They are long-distance migratory swallows, with a protected status (SPEC3) throughout Europe (BirdLife International 2017). They spend winter mostly in sub-Saharan Africa (Malo de

Molina & Martínez 2003). The dates of return and arrival at the nesting areas are variable, depending on the geographical area and annual meteorological conditions. In Spain, they arrive between mid-March and mid-April, and leave in August to mid-September (Etxezarreta 2010). The specific breeding phenology of this species in our study area is described in Figure S4.1.

Bird surveys

The presence of burrows and breeding Sand Martins was estimated through surveys on foot which covered the mining sites completely (from 800 to 8000 m, according to their surface area). Visits were conducted during breeding period, from May to July.

Each colony (i.e. groups of burrows which were separated spatially, frequently in different structures such as stockpiles, spoil heaps, etc.)

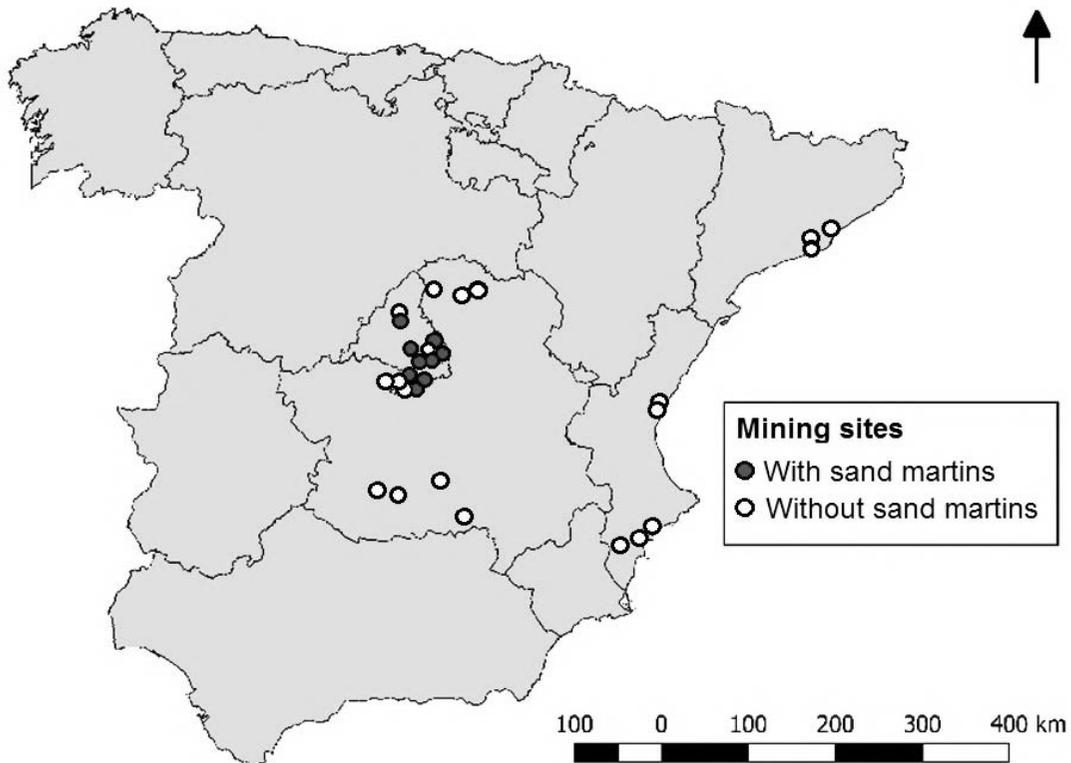

Figure 4.2 Location of the 28 mining sites. Mines with Sand Martin presence are shown in grey, without in white.

Table 4.1 Selected variables to explain Sand Martin habitat selection at the three studied scales: mining scale (m), colony scale (c), and burrow scale (b).

Ecological meaning	Variables	Scale			Hypothesis
		m	c	b	
Dispersal	Age of mining site	X			Positive effect of previous presence of Sand Martins (Szabó & Szép, 2010).
Feeding habitats	Distance to pastures	X			Positive effect of availability of concentrations of insect production and proximity to typical Sand Martin foraging areas (Waugh 1979; Hjertaas 1984; Garrison et al. 1987; Jones 1987; Lind et al. 2002; Szabó & Szép 2010; Heneberg 2013; Smalley et al. 2013; Szép 2016).
	Distance to running water	X			
	Distance to water bodies	X			
	Surface of agricultural fields	X			
	Surface of pastures	X			
	Surface of water bodies	X			
Nesting structures	Years of mining inactivity	X			Positive effect of availability of adequate nesting structures (freshly formed faces without crust, formed by materials with adequate grain, with an adequate morphology, verticality, favorable orientation, protection from predators, free of vegetation, etc.) (Hjertaas 1984; Garrison et al. 1987; Jones 1987; Lind et al. 2002; Szabó & Szép 2010; Heneberg 2013; Smalley et al. 2013; Szép 2016; Ye 2016; Burke 2017).
	Surface of the mining site	X			
	Type of extracted material in the mining site	X			
	Type of extraction at the mining site (aggregate pits, aggregate quarries and cement quarries)	X			
	Surface of extractive industry	X			
	Age of the structure		X		
	Length		X		
	Maximum height		X		
	Mean talus height		X		
	Talus height			x	
	Mean total height		X		
	Height			X	
	Mean height of the vertical surface		X		
	Height of vertical surface			X	
	Minimum height		X		
	Orientation of the structure (southwestness index)		X	X	
	Slope of vertical surface		X	X	
	Type of structure		X		
	Vegetation cover of upper area of the structure		X	X	
	Vegetation cover on the talus		X	X	
Vegetation cover on the vertical surface		X	X		
Geographical distribution	Regional Sand Martin abundance	X			Variable selected to detect geographical influence on Sand Martin presence in the mining sites.

was visited 2-5 times during the breeding season to estimate Sand Martin abundance (number of breeding pairs) and burrow occupancy (proportion of burrows containing reproduction attempts). We distinguished occupied from unoccupied burrows, based on González & Villarino (1997), by timing burrow entries and exits and recording breeding activity (presence of nestlings, fecal sacs...). In each visit, monitoring lasted one to two hours according to colony size.

Habitat selection measurements

Breeding habitat preferences were studied at three spatial scales: mining site, colony and burrow scale (Figure 4.1). Twenty-nine mining sites (aggregate pits and quarries) and their corresponding surroundings in a 1 km buffer from the perimeter of the mining site (maximum home range; Cramp 1988) were analyzed for the mining site scale. We compared 10 colonized mining sites *versus* 19 non-colonized sites, and we compared mining sites near and far from natural sites. All of the colonies in the mining sites (twenty-eight colonies) were analyzed for the colony scale and 232 sampling points for the burrow scale.

At the mining site scale, the response variables were Sand Martin abundance (Sand Martin breeding pairs) and number of burrows. We studied 13 predictor variables, including factors which could influence dispersion, and determine nesting structures and feeding habitats according to the literature (Mead 1979; Jones 1987; Szabó & Szép 2010; Heneberg 2013; Smalley et al. 2013). Land use information and distances were obtained through Corine Land Cover (IGN 2012) and measured with QGIS (QGIS Development Team 2016). All land use information and distances were obtained for the surroundings in a 1 km buffer, with exception to the presence of water bodies, which were

considered when present in the mining site itself. To calculate regional Sand Martin abundance, we used the Atlas of Spanish breeding birds (Malo de Molina & Martínez 2003). The regional Sand Martin abundance was obtained by adding the estimated pairs in the 10 X 10 km UTM grids where the mining sites were located, plus the eight surrounding grids. At the colony scale, we studied Sand Martin abundance (breeding pairs) and number of burrows as response variables. We studied whether they were related to 13 predictors considered to be indicators of adequate breeding habitat at this scale (Hjertaas 1984; Garrison et al. 1987; Jones 1987; Lind et al. 2002; Szabó & Szép 2010; Heneberg 2013; Smalley et al. 2013; Szép 2016), such as the type of structure where the colony was installed (stockpile or vertical extraction face) and variables related to its morphology (Table 4.1). Lengths and heights were measured using a rangefinder (LTI, Centennial, Colorado, U.S.A.) and slopes of the vertical surfaces with a clinometer (Silva, Bromma, Sweden). The orientation was measured with a compass, and then scaled to an index of "southwestness" (Miller & Franklin 2002). The age of the structure was estimated through interviews with quarry managers. We estimated the vegetation cover on the talus, the vertical surface, and the upper area of the structure (Figure S4.2).

At the burrow scale we established a use-availability design (Garshelis 2000). The surface of each colony was divided in two types of areas (Figure S4.3): "used area" (area with burrows) and "available area" (general structure accommodating the colony). Five equidistant sampling points were established for both areas and assigned to a binomial variable (used area vs. available area). At the ten sampling points per colony, we measured eight variables characterizing features of the face, such as height or slope (Table 4.1). Structures were classified into stockpiles or vertical extraction faces

and were analyzed separately because they had different characteristics and management regimes.

In 2017 we searched for relevant natural colonies in a 1 km buffer around the mining sites with occupied colonies. We considered natural habitats as those not created by anthropogenic activity, such as river and stream banks or lake slopes. Relevant colonies were those occupied by more than five breeding Sand Martins pairs. Afterwards, we extended our search to the entire Madrid Community (8,022 km²) by interviewing seven experts (ornithological associations and civil servants from protected areas).

Statistical analysis

Predictor variables at each scale were selected using a variable reduction procedure (García-Salgado et al. 2018) (Table S4.1). First, we selected those continuous covariates significantly related to our response variables by using Spearman's correlation and the Mann-Whitney U test for Sand Martin abundance and presence, respectively. All tests were calculated with correlation cut-off r greater than 0.6 and significance cut-off p lower

than 0.05. Second, we performed Spearman's correlations between predictors selected in the first step to avoid multicollinearity. Third, categorical predictors were selected using Chi-square tests, the non-parametric Kruskal-Wallis test, or Mann-Whitney test, according to the nature of each predictor and response variable. Finally, relationships between the selected categorical and continuous predictors were analyzed, using Chi-square test, Mann-Whitney U tests or Kruskal-Wallis tests, according to each variable. When significant relationships were found between predictors, the most significant predictor variable was selected in all the steps. The ranges of selected predictor variables at studied scales are detailed in Table 4.2. We also performed correlation matrixes of the predictor variables for each scale to depict the global interrelationships among the attributes (Figures S4.4 to S4.6). None of the predictor variables in the models at the three studied scales were correlated ($r < 0.60$).

For the mining site scale, we used Zero-inflated Poisson regression models to evaluate the influence of the selected predictor variables

Table 4.2 Ranges of the selected continuous predictor variables at the three studied scales

Scale	Predictor variable	Minimum	Maximum	Mean \pm SE
Mining site scale	Age of mining site (years)	11	87	40 \pm 3.2
	Distance to running water (m)	0	1000	596 \pm 80.1
	Distance to water bodies (m)	0	1000	772 \pm 77.5
	Surface of water bodies (ha)	0	2	0.14 \pm 0.1
	Surface of extractive industry (ha)	0	30	6 \pm 1.6
Colony scale	Orientation of the structure (southwestness index)	-0.951	0.985	-0.05 \pm 0.116
	Length of the structure (m)	16	249	96 \pm 11.2
	Vegetation cover on the vertical surface (%)	0	32	6 \pm 2
	Vegetation cover of upper area of the structure (%)	0	100	33 \pm 7
Burrow scale	Height of the vertical surface (m)	0	14	4 \pm 0.2
	Slope of vertical surface (°)	25	110	72 \pm 1

(Table 4.3) on the response variables (Sand Martin abundance and number of burrows). We selected Zero-inflated Poisson regression models due to an excess of zeros in our data, 8 sites with Sand Martins vs. 21 without (Zuur et al. 2013). At the colony scale, we used Generalized Linear Mixed Models (GLMMs) with Negative Binomial distribution to explain the response variables (Sand Martin abundance and number of burrows). The mining sites were specified as a random term to control lack of independence of the colonies in each mining site. At the burrow scale we used GLMMs for the binomial response variable. Colonies nested within mining sites

were specified as random terms to control the lack of independence associated to each colony.

For all adjusted models at the three scales, a model selection procedure based on the Akaike information criterion corrected for small sample sizes (AICc) with a 2-unit cut-off, and the parsimony criterion were applied (Burnham & Anderson 2001). Analyses were conducted using the “AICmodavg” (Mazerolle 2017), “lme4” (Bates et al. 2015), “MuMIn” (Barton 2017), “pscl” (Zeileis et al. 2008), and “visreg” (Breheny & Burchett 2017) packages in the R 3.4.0 (R Core Team 2017).

Table 4.3 For each studied scale, response variables, predictor variables introduced in the complete model, predictor variables selected in the best supported model according to AICc corrected for small samples, and the influence of the significant variables.

Response variable	Predictor variables in complete model	Predictor variables in best supported model	Influence
Mining scale			
Sand Martin abundance	Distance to running water		
	Age of mining site	Age of the mining site	Positive
1) Number of burrows	Distance to water bodies	Distance to water bodies	Negative
	Distance to running water		
	Surface of water bodies in a 1 km buffer		
	Surface of extractive industry a in 1 km buffer	Surface of extractive surface in a 1 km buffer	Positive
2) Number of burrows	Age of mining site	Age of mining site	Positive
	Type of extraction	Type of extraction	Aggregate pits > aggregate quarries > cement quarries
Colony scale			
Sand Martin abundance	Type of structure	Type of structure	Stockpiles > vertical extraction faces
	Orientation (southwestness index)	Orientation (southwestness index)	Positive
	Vegetation cover upper area		
Number of burrows	Length of structure		
	Vegetation on vertical surface	Vegetation on vertical surface	Positive
Burrow scale			
Availability versus use	Height of vertical surface		
	Slope	Slope	Positive

RESULTS

Presence and abundance in mining areas

Out of the 29 studied mining sites, ten had Sand Martin burrows, of which eight had breeding Sand Martins. These colonized mining sites were geographically grouped in the central area of the Iberian Peninsula (Figure 4.2). The occupied mining sites were located closer to running water ($p = 0.055$) and water bodies ($p = 0.067$) (marginally significant) and were in older mining sites ($p = 0.031$) (Table S4.1). Mining sites with colonies were both active and inactive. We estimated a total of 643 pairs, which varied from 0 to 249 (64 ± 26), and a total of 8,471 burrows, ranging from 38 to 2,752 (847 ± 244) (Table S4.2).

There were a total of 28 colonies in the ten mining sites, ranging from one to seven colonies per site (3 ± 0.6 colonies). Sixteen colonies had breeding Sand Martins in 2017 (occupied colonies). Sand Martin pairs per colony varied between 0 to 129 (23 ± 7.3), and the number of burrows from 6 to 1,324 (303 ± 69.1) (Table S4.3).

There was no significant relationship between the abundance of Sand Martins and the number of burrows at mining site scale ($n = 10, p = 0.92, r = 0.04$) nor at colony scale ($n = 28, p = 0.175, r = 0.26$). No relevant Sand Martin colonies were located in natural riparian habitats in the surroundings of the 28 studied colonies nor in the entire Madrid Community.

Habitat selection in mining sites

Mining Site Scale

The age of the site was included in the best supported Zero-inflated model based on AICc to explain the abundance of Sand Martins (Sand Martin breeding pairs) and their presence in the sampled mining sites ($n = 29$). The model

indicated that the age of the mining site had a positive relationship with the abundance (estimated slope = $1.01 \pm 0.07, p < 0.01$) and a marginal positive relationship with the presence of Sand Martins (estimated slope = $1.24 \pm 0.66, p = 0.059$) (Table 4.4).

Several numeric and categorical predictors were related to the number of burrows per mining site, but the categorical predictor type of extraction correlated with four numerical predictors. Thus, two Zero-inflated models were adjusted to analyze all the variables and to avoid multicollinearity between the levels of the categorical variable: 1) Including the continuous variables: distance to water bodies, distance to running water, surface of extractive industry and surface of water bodies; and 2) including the age of the site and the type of extraction (Table 4.3).

Regarding the first model, the best supported model indicated that the number of burrows had a negative relationship with the distance to water bodies (estimated slope = $-0.25 \pm 0.01, p < 0.001$) and a positive one with the surface of extractive industry (estimated slope = $0.41 \pm 0.01, p < 0.001$). The presence of burrows had a negative relationship with the distance to water bodies (estimated slope = $1.36 \pm 0.56, p = 0.02$) (Table 4.4).

Regarding the second model, the best supported model indicated that the age of the site had a positive relationship with the number of burrows per mining sites (estimated slope = $0.16 \pm 0.02, p < 0.01$) and showed significant differences between the type of extraction. The number of burrows was greater in aggregate pits (estimated slope = $3.66 \pm 0.16, p < 0.01$), followed by aggregate quarries (estimated slope = $2.75 \pm 0.16, p < 0.01$) and smaller in cement quarries (estimated slope = $3.73 \pm 0.16, p < 0.01$). Regarding the results for the presence of burrows, the selected predictor variables did not have significant effects (Table 4.4).

Table 4.4 Response variables, predictor variables introduced in the best supported models, estimated slope, standard error (SE) and Pr for the Poisson count and Logit portions of the Zero-inflated models at the mining site scale and coefficients for the GLMM at the colony and burrow scales.

Mining scale							
Response variable	Predictor variables	Poisson count model coefficients			Logit model coefficients		
		Estimate	SE	Pr(> z)	Estimate	SE	Pr(> z)
Sand Martin abundance	Intercept	4.64	0.09	p < 0.01	1.66	0.75	0.03
	Age of the mining site	0.99	0.09	p < 0.01	1.43	0.84	0.09
1) Number of burrows	Intercept	6.20	0.02	p < 0.01	0.74	0.51	0.15
	Distance to water bodies	-0.25	0.01	p < 0.01	1.36	0.56	0.02
	Surface of extractive surface in a 1 km buffer	0.41	0.01	p < 0.01	-0.76	0.50	0.13
2) Number of burrows	Intercept [Type of extraction = Aggregate pits]	3.73	0.16	p < 0.01	2.16	1.26	0.09
	Age of the mining site	0.16	0.02	p < 0.01	1.10	0.74	0.14
	Type of extraction = cement quarries	2.74	0.16	p < 0.01	-1.13	1.33	0.40
	Type of extraction = Aggregate quarries	3.66	0.16	p < 0.01	-20.04	5244.74	1.00
Colony scale							
Response variable	Predictor variables	Estimate	SE	Pr(> z)			
Sand Martin abundance	Intercept [Type of structure = Stockpiles]	3.63	0.91	p < 0.01			
	Type of structure = Vertical extraction faces	-4.06	1.58	0.01			
	Orientation (southwestness index)	1.43	0.39	p < 0.01			
Number of burrows	Intercept	5.49	0.18	p < 0.01			
	Vegetation on vertical surface	0.68	0.21	0.001			
Burrow scale							
Response variable	Predictor variables	Estimate	SE	Pr(> z)			
Availability versus use	Intercept	-3.43	0.98	p < 0.01			
	Slope	0.05	0.01	p < 0.01			

Colony Scale

Preference at colony scale was studied with the information obtained from colonies in mining sites, since natural colonies to compare with were not located in the area. The orientation, vegetation cover on the upper area of the structure and the type of structure were included in the GLMM to explain the abundance of Sand Martins in the sampled colonies ($n=28$) (Table 4.3). The best supported model showed a positive effect of the orientation of the structure (estimated slope = 1.43 ± 0.39 , $p < 0.01$), and significant differences of abundance between the type of structure ($p = 0.01$). Sand Martins showed greater abundance in stockpiles ($p < 0.01$) than in vertical extraction faces (Table 4.4).

The vegetation cover on the vertical surface was included in the best supported model to explain the number of burrows, showing a positive effect

of vegetation cover on the number of burrows (estimated slope = 0.677 ± 0.21 , $p = 0.001$) (Table 4.4).

Burrow Scale

Regarding vertical extraction faces ($n = 129$ sampling points), none of the predictor variables had a significant relationship with the binomial response variable (availability vs. use), and therefore no further analyses were performed.

For the stockpiles ($n = 103$ sampling points), we evaluated the effect of slope (Table 4.3). The best supported model showed a positive effect of the slope (estimated slope = 0.048 ± 0.01 , $p < 0.001$) (Table 4.4). The probability of finding burrows on a stockpile followed a gradient, where 70° was the turning point at which the probability of finding burrows was higher than 50% (Figure 4.3).

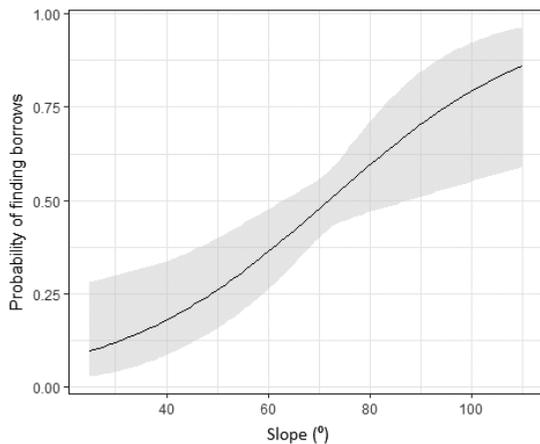

Figure 4.3 Probability of finding Sand Martin burrows as a function of the slope of the vertical surface of the structure (standardized).

DISCUSSION

Sand Martins have been increasingly using mining sites as breeding habitats. This pattern has been described in several areas of this species distribution (Hjertaas 1984; De Lope et al. 1987; González 2004; Heneberg 2007), as well as in our study area (SCV 1999; SCV 2007), where the species appears to be absent as a breeder in natural areas. Human disturbances on the river banks and the alteration of flow regimes could be explaining this change of breeding areas (Ruiz De Azua et al. 2003; SCV 2007). This highlights the importance of carrying out measures to improve habitat quality in the mining sector. Furthermore, though Sand Martins seem to be showing preference for mining sites, further studies that examine the reproductive success of Sand Martins in these environments are necessary to fully understand this phenomenon and determine whether mining sites act as surrogate habitats or habitat traps.

Breeding habitat selection in mining areas

The dispersal of the Sand Martins is favorably affected by previous conspecific presence (Szabó

& Szép 2010). Furthermore, Sand Martins are known to return to previous breeding sites and their dispersal area is not very large (10 km from previous breeding sites) (Mead 1979; Jones 1987; Szabó & Szép 2010). The age of the site showed a positive relationship with the number of burrows, as well as with the abundance of the breeding pairs, as expected. Older sites may have had more time to be occupied by Sand Martins, as well as to accumulate burrows over time, attracting other Sand Martins due to their gregarious behavior. This effect can be useful for managing Sand Martins (Appendix S4.1). Also, the occupancy levels of the burrows in our study seem lower than in other areas (Burke 2017), and future studies should be carried out as to why so many burrows are rejected.

We observed that Sand Martins showed preferences at different scales. Sand Martin's preferences for breeding habitats at larger scales, such as the mining site scale, was determined as expected by the availability of food sources. Sand Martins feed on aerial plankton (Cramp 1988) and concentrate their foraging effort wherever local concentrations of insects occur (Hjertaas 1984). We observed that mining sites closer to water, or with presence of water bodies in the sites, had larger numbers of Sand Martin burrows. We did not observe preference for other feeding areas, such as pastures (open grass fields) or agricultural fields (Garrison et al. 1987). These riparian habitats could attract Sand Martins, since they are habitats where they breed (Sáez-Royuela 1954), feed and roost (Falconer et al. 2016). Also, their presence near water bodies could be relevant in the Mediterranean context, where water is a scarce resource during the breeding season due to the characteristic summer drought, and should be taken into account when carrying out management actions for this species.

The nesting structures influenced Sand Martin breeding habitat selection at the three studied

scales. The amount of extractive areas could determine the surface of nesting habitat for Sand Martins and the possible attraction the area could exercise over them. The number of burrows was related to the type of extraction as predicted, with the aggregate sector concentrating the highest numbers of burrows. Aggregate quarries store the extracted material in large outdoor stockpiles (Herrera 2006). In addition, gravel pits have vertical sandy faces and are normally located near rivers. These results help identify which sector in the mining industry should be more conscious about Sand Martin presence in mining sites, and suggest that the aggregate sector may be the most relevant for the Sand Martins.

At colony scale, the preferred nesting structures had Southwest orientations at the studied latitudes. Most authors have not found preferences linked to colony orientation (OMNRF 2017), and therefore our finding could be relevant when proposing restoration actions for this species. We also found Sand Martin abundance was higher in stockpiles than in vertical extraction faces. Stockpiles are formed by more homogenous sandy material than vertical extraction faces (Herrera 2006), providing easier material to excavate in. Sand Martins also prefer the sandier layers in the vertical extraction faces (Blem 1979). These preferences had never been studied before and should be included in Sand Martin management programs in active mining sites. Finally, the number of burrows was higher with more vegetation cover on the vertical surface of the structures, which was not expected since colonies are located on banks with low percentage of vegetative cover (Silver & Griffin 2009). In our case, vegetation cover was low, so abandoned burrows could be acting as seed traps, or the bioturbation and biodeposition could influence the vegetation positively, as has been described for other cliff-nesting burrowing birds (Fedriani

et al. 2015). This should be analyzed in more depth in further studies, as it could be a way of promoting passive restoration.

Finally, the nesting structures at burrow scale were positively related with the verticality of the stockpiles, which coincides with the usual preference of the species (Garrison et al. 1987; Hjertaas 1984). That they were only significant preferences in stockpiles was probably because vertical extraction faces were more homogeneous for this variable (Herrera, 2006). Taking all these habitat preferences at different scales into consideration to establish restoration and management recommendations (Appendix S4.1) in the mining sites is an innovative approach, and they should be considered in the future.

Management and Restoration Recommendations

Our findings indicate that Sand Martins have a strong dependency for mining sites as breeding habitats in Mediterranean areas. This creates the need to manage this protected species both during mining and post-mining operations, especially in the aggregate sector. Based on our study, restoration actions that would benefit cliff-nesting burrowing birds would be to maintain structures where colonies have previously been located. Old structures with colonies may be repaired and enhanced, or new potential breeding areas can be designated, with slopes of at least 70°. The location should be near water sources with high insect production, orientated to the Southwest if possible. In addition to favoring this species, these conservation measures could also benefit other cliff-nesting burrowing species such as European Bee-eaters *Merops apiaster* (Casas-Crivillé & Valera 2005) and other secondary cavity nesters such as Kestrels *Falco tinnunculus*, Stock Doves *Columba oenas*, Little Owls *Athene noctua* or several species of Sparrows (Mead & Pepler 1975). These actions could be a solution to create

self-regulated systems that attract biodiversity, where cliff-nesting burrowing species would regulate the availability of nesting holes.

Promotion of biodiversity, such as cliff-nesting burrowing species, does not have to occur exclusively during post-mining operations, since individuals are attracted to active mining sites as well. Actions developed by mining companies for the Sand Martin have had positive results in the past (Hjertaas 1984; Lonchamp & Michelat 2015). Management for Sand Martins at active mining sites should be organized around an annual calendar that considers the programmed mining activities and regional Sand Martin phenology, which can vary between sites. For example, in our study area (Figure S4.1) it was slightly broader than what was reported for the Iberian Peninsula (Cramp 1988; Etxezarreta 2010).

Constructing favorable nesting structures during the reproduction period at inactive areas of mining sites, based on our results and other typical recommendations for this species, would divert Sand Martins from occupying active areas. In the same way, active areas should be maintained unfavorable, dissuading Sand Martins by reducing slopes to less than 70° and maintaining them so until mid-August when the individuals normally not initiate egg-laying. If Sand Martins occupy an active area, mining should temporarily cease until September, and the colony should be protected. In the Supplementary guide (Appendix S4.1), we propose a more detailed guideline to reconcile Sand Martin breeding in mining sites in Mediterranean areas.

To implement habitat enhancement measures which truly have a positive impact on this species, wide spread actions from the aggregate sector should be promoted. Simple habitat enhancement actions and management considerations following the recommendations of this section and Supplementary guide

(Appendix S4.1) would be very easy to implement. In Spain, these recommendations will be promoted in the aggregate sector through the National Aggregate Federation.

ACKNOWLEDGMENTS

This project was financed through a partnership between LafargeHolcim Spain, the International Foundation for the Restoration of Ecosystems (FIRE) and University of Alcalá (FORECO research group). EA was supported by a postdoctoral grant funded by the Universidad Complutense de Madrid. Special acknowledgments to Pilar Gegúndez and Raúl Pérez. Also, to Raúl Alonso, Manuel Andrés, Rafael Barrientos, Liliana Barrios, Beltrán Ceballos, Manuel Fernández, Iván García, Eloy Gómez, Miguel Ángel Letón, Patricia Orejas, José María Rey and Carlos Talabante for their contributions.

REFERENCES

- Barton K (2017) MuMIn: Multi-Model Inference. R package version 1.40.0.
- Bates D, Mächler M, Bolker B, Walker S (2015) Fitting Linear Mixed-Effects Models Using lme4. *Journal of Statistical Software* **67**:1–48
- BirdLife International (2017) European birds of conservation concern: populations, trends and national responsibilities Cambridge, UK <https://www.nabu.de/imperia/md/content/nabude/vogelschutz/170520-birds-of-conservation-concern-germany.pdf> (accessed 8 March 2018)
- Blem CR (1979) Predation of Black Rat Snakes on a Bank Swallow Colony. *The Wilson Bulletin* **91**:135–137
- Bradshaw A (2000) The use of natural processes in reclamation — advantages and difficulties. *Landscape and Urban Planning* **51**:89–100
- Bradshaw A (1996) Underlying principles of restoration. *Canadian Journal of Fisheries and Aquatic Sciences* **53**:3–9
- Breheny P, Burchett W (2017) Visualization of regression models using visreg. *The R Journal* **9**:56–71
- Bullock JM, Aronson J, Newton AC, Pywell RF and Rey-Benayas JM (2011) Restoration of ecosystem services and biodiversity: conflicts and opportunities. *Trends in*

- Ecology and Evolution* **26**(10): 541-549.
- Burke T (2017) *Bank Swallow (Riparia riparia) Breeding in Aggregate Pits and Natural Habitats*. M.Sc. Graduate Program, Trent University, Peterborough, Ontario, Canada https://digitalcollections.trentu.ca/objects/etd-553?solr_nav%5Bid%5D=83ffe292b575573596ff&solr_nav%5Bpage%5D=0&solr_nav%5Boffset%5D=0 (accessed 10 October 2018).
- Burnham KP, Anderson DR (2001) Model Selection and Multimodel Inference. A Practical Information-Theoretic Approach. *Angewandte Chemie International Edition* **40**:9823
- Casas-Crivillé A, Valera F (2005) The European bee-eater (*Merops apiaster*) as an ecosystem engineer in arid environments. *Journal of Arid Environments* **60**:227-238
- Castillo I, Elorriaga J, Zuberogoitia I, Azkona A, Hidalgo S, Astorkia L, Iraeta A, Ruiz F (2008) Importancia de las canteras sobre las aves rupícolas y problemas derivados de su gestión. *Ardeola* **55**:103-110
- Cramp S (1988) *Handbook of the birds of Europe, the Middle East and North Africa. The birds of the Western Palearctic*. Oxford University Press, Oxford, United Kingdom
- Donovan TM, Thompson III FR (2001) Modeling the ecological trap hypothesis: a habitat and demographic analysis for migrant songbirds. *Ecological Applications* **11**:871-882
- Ettxezarreta J (2010) Distribución y situación actual del avión zapador (*Riparia riparia*) en la Vertiente Cantábrica del País Vasco. *Munibe* **58**:149-171
- Falconer CM, Mitchell GW, Taylor PD, Tozer DC (2016) Prevalence of Disjunct Roosting in Nesting Bank Swallows (*Riparia riparia*). *The Wilson Journal of Ornithology* **128**:429-434
- Fedriani JM, Garrote PJ, Delgado MdM, Penteriani V (2015) Subtle gardeners: Inland predators enrich local topsoils and enhance plant growth. *PLoS ONE* **10**(9):e0138273
- García-Salgado G, Rebollo S, Pérez-Camacho L, Martínez-Hesterkamp S, De la Montaña E, Domingo-Muñoz R, Madrigal-González J, Fernández-Pereira M (2018) Breeding habitat preferences and reproductive success of Northern Goshawk (*Accipiter gentilis*) in exotic Eucalyptus plantations in southwestern Europe. *Forest Ecology and Management* **409**:817-825
- Garrison BA, Humphrey JM, Laymon SA (1987) Bank Swallow Distribution and Nesting Ecology on the Sacramento River, California. *Western Birds* **18**:71-76
- Garshelis DL (2000) Delusions in habitat evaluation: Measuring use, selection, and importance. Pages: 111-164. In: *Research techniques in animal ecology: Controversies and consequences*. Columbia University Press, New York, New York
- González JL (2004) El avión zapador (*Riparia riparia*) en Extremadura. Problemática y propuestas de conservación. In: *Congreso sobre especies protegidas en Extremadura*. Trujillo, Spain
- González S, Villarino A (1997) Nidotópica y situación actual del Avión Zapador *Riparia riparia* (L. 1758), en la Provincia de Ourense (NO España). *Ardeola* **44**:41-49
- Heneberg P (2007) Sand martin (*Riparia riparia*) in the Czech Republic at the turn of the millenium. *Linzer Biologische Beiträge* **39**:293-312
- Heneberg P (2013) Decision making in burrowing birds: Sediment properties in conflict with biological variables. *Quaternary International* **296**:227-230
- Herrera J (2006) Métodos de la Minería a Cielo Abierto. Universidad Politécnica de Madrid, Escuela Superior de ingenieros de Minas, Madrid, Spain http://oa.upm.es/110675/1/20111122_METODOS_MINERIA_A_CIELO_ABIERTO.pdf (accessed 8 August 2018)
- Hjertaas DG (1984) Colony Site Selection in Bank Swallows. PhD Dissertation, University of Saskatchewan, Saskatoon, Saskatchewan, Canada <https://core.ac.uk/download/pdf/55300816.pdf> (accessed 3 March 2018)
- IGN (Instituto Geológico Nacional) (2012) Centro de Descargas del CNIG. <http://centrodedescargas.cnig.es/CentroDescargas/index.jsp> (accessed 30 August 2017)
- Jones G (1987) Colonization patterns in sand martins *riparia riparia*. *Bird Study* **34**:20-25
- Lind B-B, Stigh J, Larsson L (2002) Sediment type and breeding strategy of the Bank Swallow *Riparia riparia* in western Sweden. *Ornis Svecica* **12**:157-163
- Lonchamp F, Michelat D (2015) *La nidification de l'hirondelle de rivage dans les environs de Pontarlier en 2015*. LPO Franche-Comté (ed). Besançon, France <https://cdnfiles1.biolovision.net/franche-comte.lpo.fr/userfiles/observer/Hirondelles/Bilan2015SuiviRipariaDrugeon.pdf> (accessed 13 April 2016)
- De Lope F, Fernández A, De La Cruz C (1987) La situación del avión zapador (*Riparia riparia*) en Extremadura. *Alytes* **5**:121-132
- Lundholm JT, Richardson PJ (2010) Habitat analogues

- for reconciliation ecology in urban and industrial environments. *Journal of Applied Ecology* **47**:966–975
- Malo de Molina J, Martínez J (2003) Avión Zapador *Riparia riparia*. Pages 380–381 In: Martí R, Moral J (eds) *Atlas de las aves reproductoras de España*. Dirección General de Conservación de la Naturaleza-SEO, Madrid, Spain
- Mazerolle MJ (2017) AICcmmodavg: Model selection and multimodel inference based on (Q)AIC(c). R package version 2.1-1.
- McRae SG (1986) Opportunities for Creative Reclamation Following Sand and Gravel Extraction. In: *New Horizons for mined Land Reclamation*. In: Harper J, Plass, B (eds) *Procedures National Meeting American Society for Surface Mining and Reclamation*, Princeton, West Virginia
- Mead CJ, Pepler (1975) Birds and other animals at Sand Martin colonies. *British Birds* **68**:89–99
- Mead CJ (1979) Colony fidelity and interchange in the Sand Martin. *Bird Study* **26**:99–106
- Miller J, Franklin J (2002) Modeling the distribution of four vegetation alliances using generalized linear models and classification trees with spatial dependence. *Ecological Modelling* **157**:227–247
- Nentwig W, ed. (2007) *Biological Invasions*. Springer, Berlin Heidelberg, Germany
- OMNRF (Ontario Ministry of Natural Resources and Forestry) (2017) *Best Management Practices for the Protection, Creation and Maintenance of Bank Swallow Habitat in Ontario*. Queen's Printer for Ontario, Ontario, Canada <https://www.ossqa.com/multimedia/2017-03-27-100504-95129/bansbmpenpdffinal.1.117mar17.pdf> (accessed 24 October 2017)
- QGIS Development Team (2016) QGIS Geographic Information System. Open Source Geospatial Foundation Project <http://qgis.osgeo.org>
- R Core Team (2017) R: A language and environment for statistical computing. R Foundation for Statistical Computing, Vienna.
- Ruiz De Azua N, Fernández JM, Bea A, Carreras J (2003) Situación de la población nidificante de avión zapador *Riparia riparia* en Álava. Pages 57–66. In: Diputación Foral de Álava (ed) *Proceedings of the Ornithology Meeting in Álava*. Vitoria-Gasteiz, Spain
- Sáez-Royuela R (1954) Notas sobre el Avión Zapador; *Riparia riparia* (L.), en la Península Ibérica. *Munibe* **6**:253–262
- SCV (Sociedad para la Conservación de Vertebrados) (1999) Situación actual del avión zapador (*Riparia riparia*) en la comunidad de Madrid. Pages 72–77. In: SEO-Monticola (ed) *Anuario Ornitológico de Madrid*, Madrid, Spain
- SCV (Sociedad para la Conservación de Vertebrados) (2007) Censo de avión zapador (*Riparia riparia*) en la Comunidad de Madrid, Madrid, Spain <https://scv-conservacion.webcindario.com/avionzapador/zapador2007.html> (accessed 1 August 2018)
- Silver M, Griffin CR (2009) Nesting Habitat Characteristics of Bank Swallows and Belted Kingfishers on the Connecticut River. *Northeastern Naturalist* **16**:519–534
- Smalley I, Blake-Smalley R, O'Hara-Dhand K, Jary Z, Svircev Z (2013) Sand martins favour loess: How the properties of loess ground facilitate the nesting of sand martins/bank swallows/uferschwaben (*Riparia riparia* Linnaeus 1758). *Quaternary International*, **296**:216–219
- Szabó Z, Szép T (2010) Breeding dispersal patterns within a large Sand Martin (*Riparia riparia*) colony. *Journal of Ornithology* **151**:185–191
- Szép T, Für J, Molnár E (2016) A high level of nest predation observed in a large Sand Martin (*Riparia riparia*) colony. *Ornis Hungarica* **24**:46–53
- Waugh DR (1979) The diet of Sand Martins during the breeding season. *Bird Study* **26**:123–128
- Ye SY, Guo SI, Dou ZL, Wang ZL, Lu JQ (2016) Nest-site selection of Sand Martin (*Riparia riparia*) in the suburbs of Zhengzhou, Henan. *Acta Ecologica Sinica* **36**(21):1–8
- Yundt SE, Lowe SB (2002) Quarry rehabilitation - Cliffs, landforms and ecology. Pages: 129–139. In: The Technical and Research Committee on Reclamation (ed) *26th Annual British Columbia Mine Reclamation Symposium, Dawson Creek, 2002*, British Columbia, Canada
- Zeileis A, Kleiber C, Jackman S (2008) Regression Models for Count Data in R. *Journal of Statistical Software* **27**:1–25
- Zuur AF, Hilbe JM, Ieno EN (2013) *A Beginner's Guide to GLM and GLMM with R*. Springer-Verlag New York

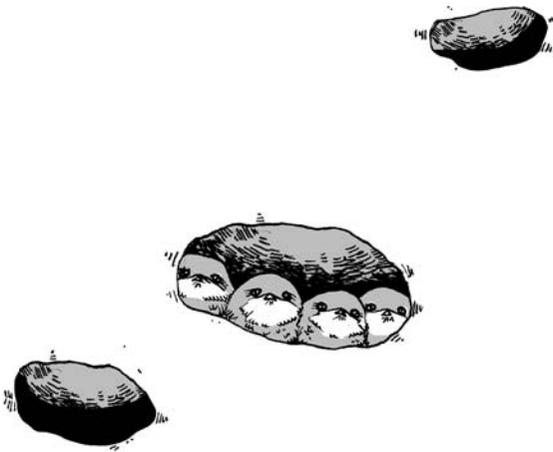



CHAPTER V

Bird services applicable to mining restoration: The Sand Martin (*Riparia riparia*) burrow construction case study

CHAPTER V

Bird services applicable to mining restoration: The Sand Martin (*Riparia riparia*) burrow construction case study

Rohrer, Z.¹, Rebollo, S.¹, Andivia, E.², Franco, J., Rodríguez Urquía, C.

¹Forest Ecology and Restoration Group, Departamento de Ciencias, Universidad de Alcalá, Madrid, Spain.

²Departamento de Biodiversidad, Ecología y Evolución, Universidad Complutense de Madrid, Madrid, Spain.

ABSTRACT

Mining sites can be colonized by cliff-nesting birds if they provide habitat requirements, such as safe nesting cavities. Colonization of mining areas by secondary cliff-nesting birds could be limited by the abundance of safe cavities. However, certain burrowing birds could provide ecological services, by constructing adequate nesting places for secondary cavity-nesting birds. Our objective was to study the availability of burrows of biotic origin in mining sites, and their role in improving colonization and local biodiversity of cliff-nesting birds. We selected the Sand Martin because it is a colonial engineer species that nests frequently in mining sites. First, we estimated Sand Martin burrow abundance and occupation rates and identified secondary cavity-nesting birds in 8849 burrows from 30 colonies, in 10 mining sites in central Spain; second, we studied the dynamic of the Sand Martin burrows, by estimating annual construction and disappearance rates; and finally, we studied factors that could favour secondary cavity-nesting bird occupation. We found that Sand Martins burrowed more than was previously estimated in mining sites, and their burrows were used by five species of secondary cavity-nesting birds. The number of available burrows each year varied, due to relatively high annual construction and disappearance rates. Numbers of Sand Martin pairs and burrows in the colonies were the main factors favouring secondary occupation. Our results support promoting Sand Martins in mining restoration projects, not only to benefit this endangered bird, but also because their ecosystem services would benefit other species, thus increasing local biodiversity of cliff-nesting birds.

Key words Cavity-nesting birds, cliff-nesting birds, ecological restoration, ecosystem services, secondary users.

INTRODUCTION

Ecosystem engineers affect other organisms by modulating the availability of resources to other species (Jones et al. 1994). These engineer species can help revert impacts on degraded ecosystems through the ecosystem services they provide. For example, with its burrowing activity, the Eastern Bettong (*Bettongia gaimardi*) can have profound effects on water infiltration and seed germination, helping restore temperate woodlands in Australia (Manning et al. 2001), and the restoration of biological soil crusts with Cyanobacteria in degraded drylands can contribute the recovery of ecosystem functions, such as erosion resistance and nutrient cycling (Chiquoine et al. 2016). Despite recognition of important services provided by engineer species, they have received little attention, and the ecosystem engineering concept has been rarely incorporated into habitat improvement, conservation and ecological restoration projects (Byers et al. 2006).

Birds are probably the group of terrestrial vertebrates with the most diverse range of ecological functions (Sekercioglu 2006). These functions can provide many ecosystem services, including trophic-related services such as seed dispersion, pollination or nutrient cycling (Whelan et al. 2008). Also, they can provide valuable non-trophic related services, such as generating potential refuge for fauna (Wenny et al. 2011). Thus, the nest building activity of some birds creates burrows that can be used by many other secondary cavity-nesting species, who need holes for shelter or reproduction but have no capacity to build them (Casas-Crivillé and Valera 2005).

Cliff-nesting birds, many of which are protected in their distribution ranges (Madroño et al. 2004), frequently colonize cliff habitats created by mining activity. Mining areas can provide

these species with habitats similar to the ones found in natural environments, if the former maintain certain ecological characteristics, such as an adequate supply of holes and ledges where they can nest (Castillo et al. 2008). Despite this, the importance of mining areas as breeding areas for cliff-nesting birds is usually ignored and undervalued, contributing to increase the vulnerability of the species that colonize them (Castillo et al. 2008). Including habitat improvement for cliff-nesting birds in mining restoration projects can be an effective way of contributing to the conservation of some of these protected species. In turn, this management can take advantage of ecosystem services provided by some cliff-nesting birds to achieve restoration objectives.

In this study we focus on the Sand Martin (*Riparia riparia*), a threatened migratory bird (BirdLife International 2017), that nests in colonies located almost exclusively in mining sites (Suvorov et al. 2011) where it carries out an intense burrowing activity. To the best of our knowledge, there are very few studies regarding the secondary cavity-nesting species of Sand Martin burrows and their relevance towards them. Sand Martins could be a good model to study potential environmental services of birds in mining restoration because they could facilitate the colonization of mining sites by other cliff-nesting species and enhance local biodiversity.

The colonization of mining areas by secondary cliff-nesting birds could be limited by the abundance of holes, such as has been described for other secondary cavity-nesting species in non-mining environments (Cockle et al. 2010). In mining areas, holes are generated mainly by mining activity, but also by abiotic (e.g. water erosion) and biotic agents (e.g. burrowing species). Burrowing species (primary cavity-nesting species) could increase local biodiversity of cliff-nesting animals because their burrowing

activity would increase the availability of holes for secondary cavity-nesting species (Hansell 1993).

Our overall objective is to study the availability of burrows of biotic origin in mining sites, and their possible role in improving the local biodiversity of cliff-nesting birds. The specific objectives were to 1) estimate Sand Martin burrow abundance and Sand Martin occupation rate in mining areas; 2) identify secondary cavity-nesting birds using Sand Martin burrows and their burrow occupation rates; 3) study the dynamic of the Sand Martin burrows in the colonies by estimating the annual construction and disappearance rates of burrows, and 4) determine factors that favour the burrow occupation by secondary cavity-nesting species. The studied factors that could affect secondary occupation were: a) Sand Martin abundance, which would affect positively by providing other advantages to the secondary cavity-nesting species such as group defence against predators (Brown and Brown 2001); b) Burrow abundance, which would affect positively because areas with more burrows could attract more secondary cavity-nesting species; c) The type of structure where the colony is located (vertical extraction face or stockpile), since each type of structure may differ in the amount of available holes from other origins, such as mining activity; d) The age of the structure, which could also affect positively, conditioning the available time for Sand Martins and secondary cavity-nesting species to colonize the structures.

If Sand Martin burrows are used by other cliff-nesting species, it would justify including this burrowing bird in mining restoration projects, not only because the populations of this endangered species would be promoted, but also because the ecosystem services they provide would benefit other species, thus possibly increasing local biodiversity of cliff-nesting birds.

MATERIALS AND METHODS

Study area

This study was conducted in the period of 2016 -2017 in 10 mining sites in central Spain with presence of Sand Martin burrows (Figure 5.1). The elevation of the mining sites ranged from 500 to 840 m.a.s.l. The climate was Mediterranean, and the daily mean temperature and annual precipitation ranged between 10.2 and 14.9 °C, and between 401 to 524 mm, respectively. The extracted materials were granite, limestone, sand and gravel. Sites varied in size from 23 to 100 ha. Each occupied mining site usually had several Sand Martin colonies that were separated spatially, frequently in different structures (mainly vertical extraction faces, stockpiles and spoil heaps). The age of the structures was estimated through interviews of the mining managers.

Sand Martin and secondary nesting bird abundances and occupation rates

The breeding populations of Sand Martins and secondary cavity-nesting species were estimated during the breeding period in Spain – May to July (González and Villarino 1997). Each site was visited 2-5 times. At each colony, burrow occupation (proportion of nesting burrows containing reproduction attempts) of Sand Martins and secondary cavity-nesting species was estimated. We distinguished occupied from unoccupied burrows based on González and Villarino (1997). We used the burrow occupation to estimate the abundance of Sand Martins and secondary cavity-nesting species, considering that each pair occupied only one burrow. Burrows (both occupied and unoccupied) were counted at each colony by taking overlapping photographs. Mean burrow density by square meter was calculated for the vertical surfaces of

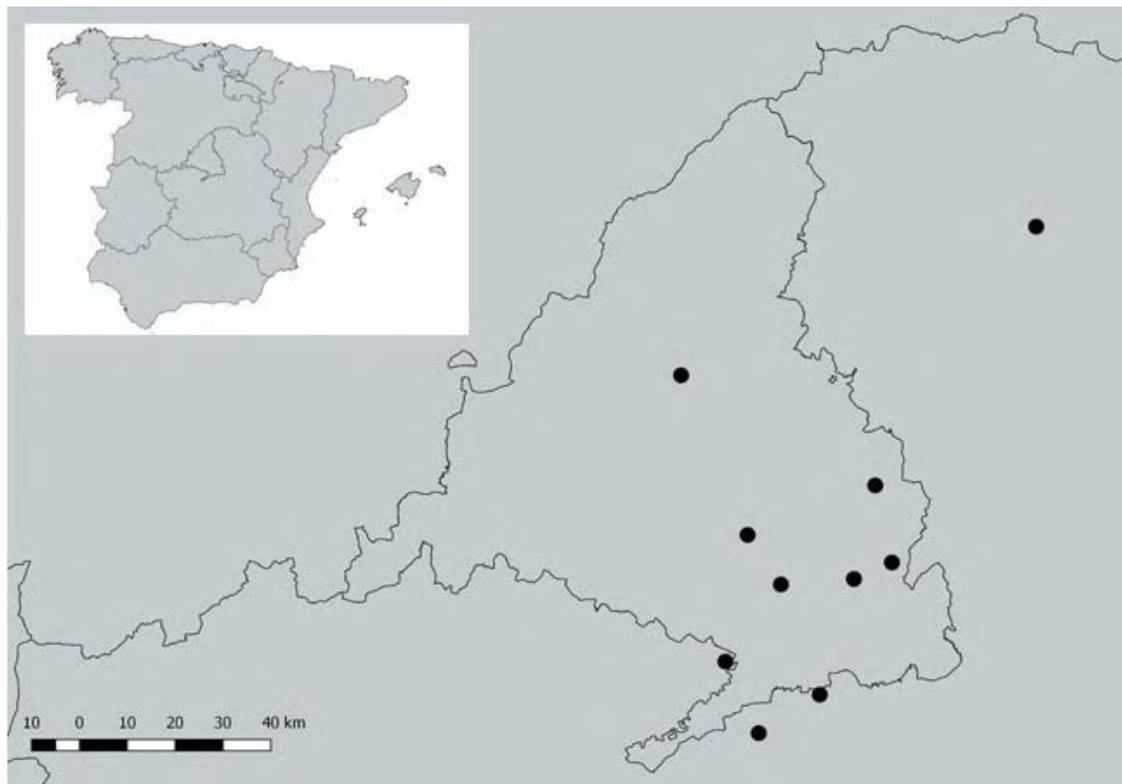

Figure 5.1 Location of the 10 mining sites with Sand Martin colonies in central Spain

the colonies (total number of burrows divided by the vertical surface of the colony) (Figure S5.1). Maximum density of burrows was also measured at the six densest colonies in one square meter per colony. We used Spearman's correlation to test whether Sand Martin and burrow abundances were related.

Annual construction and disappearance rates of Sand Martin burrows

We compared photographs of the colonies taken in 2016 with those taken in 2017 for those sections of the colonies for which we had good quality images in 2016. We applied the following equations to calculate the construction and disappearance rates:

$$\text{Disappearance rate (\%)} = \frac{\text{number of disappeared burrows in 2017} \times 100}{\text{number of existing burrows in 2016}}$$

$$\text{Construction rate (\%)} = \frac{\text{number of constructed burrows in 2017} \times 100}{\text{number of existing burrows in 2017}}$$

We used Spearman's correlation to test the relationship between the burrow construction and disappearance rates, and to test the relationship between the burrow disappearance and construction rates and Sand Martin occupation rate.

Factors favouring abundance and occupation rates of secondary cavity-nesting bird species

The analyses were carried out considering the colony scale (30 colonies in the 10 mining sites). Three response variables were selected: secondary cavity-nesting species abundance and richness, and occupation rate of Sand Martin burrows. A specific analysis was performed for the Rock Sparrow (*Petronia petronia*) abundance and occupation rate, because it was the secondary species with the most abundance. We analysed the following predictor variables: Sand Martin abundance, burrow abundance, age

of the structure and type of structure (stockpile or vertical extraction face). We performed Spearman's correlations and the Mann-Whitney U test between the predictor variables and eliminated the type of structure because it correlated with the Sand Martin abundance and age of the structure. All tests were calculated with significance cut-off of $p < 0.05$, and the correlation cut-off was $r > 0.6$.

We used Generalized Linear Mixed Models (GLMM) to analyse the influence of the selected predictor variables on the response variables. For secondary cavity-nesting species abundance and richness and Rock Sparrow abundance, we used Generalized Linear Mixed Models (GLMMs) with Poisson distribution. For the secondary cavity-nesting species occupation and Rock Sparrow occupation, we used GLMMs with a Binomial distribution. Mining sites were specified as a random term to control lack of independence of the colonies in each mining site. For all adjusted models, we applied a model selection procedure based on the Akaike information criterion corrected for small sample sizes (AICc) with a 2-unit cut-off (Burnham and Anderson 2001). Analyses were conducted using the "lme4" (Bates et al. 2015) and "MuMIn" (Barton 2017) packages in the R 3.4.0 (R Core Team 2017).

RESULTS

Sand Martin burrow abundance and Sand Martin occupation rate in mining sites

Out of the 10 mining sites with Sand Martin burrows we detected breeding pairs in eight. A total of 8849 burrows were studied, with burrow numbers varying from 38 to 2752 (mean \pm SE, 247 ± 885 burrows) per mining site (Table 5.1). The total Sand Martin abundance was 680 pairs, with figures ranging between 4 and 249 pairs

(85 ± 30 pairs) per mining site (Table 5.2). A total of 30 colonies were identified, ranging from one to seven colonies per mining site (3 ± 0.6 colonies). The number of burrows varied from 6 to 1324 (295 ± 65 burrows) between colonies. Of the 30 colonies, 16 (53%) were occupied by Sand Martins in 2017. The number of pairs in the 16 colonies varied from 1 to 129 pairs (40 ± 10 pairs). The Sand Martin abundance and number of burrows was not correlated neither at the mining site scale ($n = 10$, $r = 0.01$, $p = 0.97$) nor colony scale ($n = 30$, $r = 0.31$, $p = 0.09$). The Sand Martin occupation rates in the mining sites reached 47.7% when present ($12 \pm 5\%$) (Table 5.2).

The vertical surface of the structure where the 30 colonies were located varied between 12 and 941 m² (269 ± 50 m²). The mean burrow density per square meter of the vertical surfaces varied between 0.1 and 8.8 (2.0 ± 0.4 burrows/m²) (Table 5.1). The maximum density per square meter varied between 20 and 34 burrows/m² ($n = 6$, 24 ± 2 burrows/m²) (Table S5.1). Colonies were in 12 stockpiles and 18 vertical extraction faces. The age of the structures varied between 0.5 to 13 years (5 ± 0.6 years), with most being between 3 to 8 years old (64%) (Table 5.1). Other variables regarding the colonies' characteristics are shown in Table S5.2.

Secondary cavity-nesting bird species in the Sand Martin burrows

Five secondary cavity-nesting bird species were observed in the 10 studied mining sites. In order of abundance: Rock Sparrow (*Petronia petronia*), House Sparrow (*Passer domesticus*), Eurasian Tree Sparrow (*P. montanus*), Little Owl (*Athene noctua*) and Black Redstart (*Phoenicurus ochruros*) (Table 5.2).

At the mining site scale, 70% of the mining sites had secondary cavity-nesting species and the

Table 5.1 Number of burrows, Sand Martin pairs, age and type of structure of the 30 colonies. Mining sites are ordered alphabetically. Colonies are ordered in increasing number of burrows per mining site

Mining site	Colony	no. of burrows	Sand Martin pairs	Vertical surface (m ²)	Burrow density (burrows/m ²)	Age of structure (years)	Type of structure
COR	COR2	40	5	40	1.0	8	stockpile
	COR5	40	0	279	0.1	10	vertical face
	COR6	240	0	346	0.7	6.5	vertical face
	COR4	243	2	674	0.4	9	vertical face
	COR3	328	38	333	1.0	13	vertical face
	COR1	409	63	125	3.3	3.5	stockpile
CTO	CTO1	38	4	38	1.0	9	vertical face
EMO	EMO1	1070	40	405	2.6	3	stockpile
EPU	EPU2	50	0	941	0.1	3.5	vertical face
	EPU3	227	0	790	0.3	5	vertical face
	EPU1	293	0	505	0.6	3.5	vertical face
ESP	ESP3	6	0			1	stockpile
	ESP2	43	0	229	0.2	4	vertical face
	ESP1	316	124	173	1.8	0.5	stockpile
LCH	LCH3	10	1	19	0.5	6.5	stockpile
	LCH2	67	1	94	0.7	6.5	stockpile
	LCH1	84	4	96	0.9	9	stockpile
LPO	LPO2	105	34	12	8.8	4	stockpile
	LPO1	811	91	240	3.4	4	vertical face
MAT	MAT3	117	50	55	2.1	0.5	stockpile
	MAT2	168	70	44	3.8	3	stockpile
	MAT1	237	129	39	6.1	3	stockpile
PRE	PRE1	1155	0	373	3.1	6.5	vertical face
ROM	ROM6	30	0	28	1.1	8	vertical face
	ROM3	83	0	930	0.1	2	vertical face
	ROM2	84	1	81	1.0	2	vertical face
	ROM8	143	0	165	0.9	8	vertical face
	ROM5	510	0	224	2.3	4	vertical face
	ROM1	578	24	87	6.6	1.5	vertical face
	ROM7	1324	0	450	2.9	8	vertical face
Total	30	8849	680				

Table 5.2 Pairs and occupation of Sand Martin and secondary cavity-nesting species per mining site. Total secondary cavity-nesting species pairs, secondary cavity-nesting species richness and secondary cavity-nesting species occupation rate (Occup. rate) per mining site. Mining sites are ordered in ascending order of secondary cavity-nesting species pairs. Secondary species are ordered regarding their total abundance

Mining site	Sand martin		Rock sparrow		House sparrow		Eurasian tree sparrow		Little owl		Black redstart		Total secondary cavity-nesting species pairs	Secondary cavity-nesting species richness	Secondary cavity-nesting species occupation
	Pairs	Occup. rate	Pairs	Occup. rate	Pairs	Occup. rate	Pairs	Occup. rate	Pairs	Occup. rate	Pairs	Occup. rate			
CTO	4	10.5	0	0	0	0	0	0	0	0	0	0	0	0	0
EPU	0	0	0	0	0	0	0	0	0	0	0	0	0	0	0
PRE	0	0	0	0	0	0	0	0	0	0	0	0	0	0	0
ROM	25	0.9	0	0	0	0	2	0.1	0	0	0	0	2	1	0.1
LCH	5	3.1	3	1.9	0	0	0	0	0	0	0	0	3	1	1.9
MAT	249	47.7	4	0.8	0	0	0	0	0	0	0	0	4	1	0.8
ESP	124	34	8	2.2	1	0.3	0	0	0	0	0	0	9	2	2.5
COR	108	8.3	8	0.6	4	0.3	1	0.1	0	0	0	0	13	3	1
LPO	125	13.6	28	3.1	0	0	0	0	2	0.2	0	0	30	2	3.3
EMO	40	3.7	46	4.3	0	0	0	0	0	0	1	0.1	47	2	4.4
Total	680	7.7	97	1.1	5	0.1	3	0	2	0	1	0	108	5	1.2

highest richness was 3 species. None of the secondary cavity-nesting species was present in all the mining sites. The Rock Sparrow was the most abundant secondary cavity-nesting species, being present in 6 mining sites. In general, the secondary cavity-nesting species had low burrow occupation rates at mining site level, with the Rock Sparrow reaching the maximum of 4.3% (Table 5.2). At colony level, secondary cavity-nesting species appeared in 14 out of 30 colonies (46.7%) (Table S5.3). The Rock Sparrow was the most frequent secondary cavity-nesting species, appearing in 11 colonies (36.7%). When present, the occupation rates of the Rock Sparrow in the colonies varied from 0.6% to 4.3% ($0.8 \pm 0.2\%$), while the Sand Martin occupation rates varied between 0.8 to 54.4 % ($9.6 \pm 3\%$) (Table S5.3).

Dynamic of Sand Martin burrows: annual construction and disappearance rates of burrows

The construction and disappearance rates were estimated in 17 colonies belonging to 9 mining sites (Table 5.3). At the mining site scale, the annual construction rate varied between 0 and 57% ($17 \pm 6\%$) and the annual disappearance rate between 0 and 30% ($14 \pm 3\%$). The number of burrows increased from 2016 to 2017 in 5 mining sites (56%). At the colony scale, the annual construction rate varied from 0 to 50% ($9 \pm 3\%$) and the disappearance rate varied from 0% to 30% ($8 \pm 2\%$). The number of burrows increased in 8 colonies (47%).

Table 5.3 Annual construction and disappearance rates of Sand Martin burrows in the period 2016-2017. Colonies are ordered in ascending number of burrows in 2016

Colony	No. Burrows 2016	Sand Martin pairs	Disappeared burrows in 2017	Disappearance rate (%)	No. Burrows 2017	New burrows in 2017	Construction rate (%)
ROM6	3	0	0	0	6	3	50
LCH3	12	40	2	17	10	0	0
EPU2	18	63	1	6	17	0	0
CTO1	36	1	0	0	38	2	5
ESP2	44	91	2	5	43	1	2
LCH2	59	2	1	2	67	9	13
LCH1	81	4	0	0	84	3	4
ROM8	161	4	19	12	143	1	1
EPU1	196	0	21	11	175	0	0
COR4	229	24	0	0	243	14	6
COR1	400	0	88	22	409	97	24
ROM1	411	0	13	3	410	12	3
ROM5	531	0	27	5	510	6	1
EMO1	784	0	15	2	1070	301	28
LPO1	793	0	77	10	811	95	12
ROM7	1330	0	27	2	968	21	2
PRE1	1600	0	482	30	1155	37	3

The construction and disappearance rates were not significantly related neither at the mining site ($n = 9, r = 0.24, p = 0.53$) nor at the colony scale ($n = 17, r = -0.44, p = 0.07$). The disappearance rate and the Sand Martin occupation rate were not significantly related at the mining site nor colony scales ($n = 9, r = -0.05, p = 0.9$, and $n = 17, r = -0.23, p = 0.37$, respectively). The construction rate and the Sand Martin occupation were not related at the mining site scale ($n = 9, r = 0.61, p = 0.08$), but showed a significant positive relationship at the colony scale ($n = 17, r = 0.63, p < 0.01$).

Factors that favour the occupation of secondary cavity-nesting species

Sand Martin abundance and the age of the structure were related to the type of structure ($W = 174, P < 0.01$ and $W = 59, p = 0.04$, respectively) (Table S5.4). Consequently, and to avoid multicollinearity we did not include the type of structure in the models. The abundance of Sand Martins and the number of burrows were included in the GLMMs to explain the factors which could affect secondary nesting species abundance. The best supported Poisson GLMM (Table S5.5) determined that secondary nesting species abundance had a positive relationship with Sand Martin abundance (estimated slope = 0.81, SE = 0.21, $p < 0.001$) and number of burrows (estimated slope = 0.86, SE = 0.25, $p < 0.001$). The best fitted Poisson GLMM for secondary cavity-nesting species richness (Table S5.6) included Sand Martin abundance, which showed a positive relationship with the richness (estimated slope = 0.5, SE = 0.17, $p < 0.001$). The Negative Binomial GLMM which best explained secondary cavity-nesting species' occupation (Table S5.7) included Sand Martin abundance. This variable showed a positive relationship with the occupation (estimated slope = 0.5, SE = 0.22, $p < 0.02$).

The abundance of Sand Martins, the number of burrows and the age of the structure were included in the models to analyse Rock Sparrow abundance and occupation. The best supported Poisson GLMM model (Table S5.8) indicated that the abundance of Rock Sparrows was explained by a positive relationship with the abundance of Sand Martins and the number of burrows (estimated slope = 0.53, SE = 0.23, $p = 0.02$, and estimated slope = 1.03, SE = 0.33, $p < 0.01$, respectively) and a negative relationship with the age of the structure (estimated slope = -0.63, SE = 0.33, $p = 0.02$). The best fitted Binomial GLMM model for the Rock Sparrow occupation (Table S5.9) included the age of the structure, which showed a negative relationship (estimated slope = -0.85, SE = 0.36, $p = 0.02$).

DISCUSSION

The Sand Martin showed an elevated burrowing activity in the mining sites and their burrows were used both by the Sand Martin and five species of secondary cavity-nesting birds. The number of available burrows each year varied, due to relatively high annual construction and disappearance rates. The abundance of Sand Martin pairs and burrows in the colonies were the principal factors which favoured the secondary cavity-nesting species occupation. These results support the interest of including the Sand Martin in the management and restoration of mining sites.

Sand Martin burrow abundance and occupation rate in mining areas

To the best of our knowledge, information regarding presence of Sand Martins and their burrows in mining areas is not common in the literature. We found 30 colonies in our study area and observed that Sand Martins could excavate almost 9000 burrows in the 10 mining

sites, with an average of 900 burrows per site. This result is higher than the average that has been described for mining sites in the literature, which ranges from 7.5 to 112 (Hjertaas 1984, García and Álvarez 2000, Burke 2017). Regarding the density of burrows, we found similar results to the existing literature (Cramp 1988, González and Villarino 1997), but this could be due to the applied measuring system, since these authors use the minimum rectangle that includes the burrows, whereas we used the entire available vertical surface. We did find very high maximum densities per square meter (Table S5.1), demonstrating the elevated capacity of the Sand Martin to construct large groups of burrows in mining sites. The low values regarding burrow abundance and density in the literature may be underestimating the relevance of the Sand Martin's presence in mining sites and its potential to provide nesting places for cavity-nesting bird species.

Secondary cavity-nesting bird species using Sand Martin burrows

Sand Martins provided nesting places for a community of secondary cavity-nesting bird species in mining areas in a similar way Sand Martins do in natural areas. In this work, we detected five secondary cavity-nesting bird species, which had lower burrow occupation rates than the Sand Martin. Though other authors refer to a higher number of secondary cavity-nesting species using Sand Martin burrows (Mead and Pepler 1975, Suvorov et al. 2011), it is because these studies use a national scale approach. Our results are in the expected range when compared to other studies with similar scale (Hjertaas 1984). The secondary cavity-nesting species we observed coincide the literature, such as the Eurasian Tree Sparrow (Piotrowski et al. 2011), the House Sparrow

(Cordero Tapia 1986), and the Rock Sparrow (Cano Sánchez 2003).

As well of these species with a similar size to the Sand Martin, we observed larger species in low densities occupying the Sand Martin burrows, such as the Little Owl. In some cases, these larger species used the larger burrows formed after erosion (Mead and Pepler 1975). In other cases, the secondary cavity-nesting species can adjust the size of the burrows, as has been described for the European Bee-eater (*Merops apiaster*) (Blancat et al. 1995) or the Jackdaw (*Corvus monedula*) (Soler 2014). Over time, the natural erosion and the action of other species might modify the size of some burrows and increase the range of species which can benefit from the Sand Martin burrows.

Dynamic of Sand Martin burrows

The annual construction and disappearance rates of Sand Martin burrows is something that to the best of our knowledge has not been studied deeply before. At a colony scale, we found construction and disappearance rates per year up to 50% and 30%, respectively. We did not find a significant relationship between the construction and disappearance rates, which indicates that the construction activity does not try to compensate the disappearance of old burrows. As these high construction/disappearance rates make the inter-annual availability of burrows highly variable, we believe that burrows are not a stable resource and therefore, maintaining Sand Martins is required to conserve the availability of burrows and the potential of accommodating other species over time. Studying the factors that regulate these local dynamics should be a future line of research because of its direct repercussions for the management of this species and the promotion of secondary cavity-nesting species.

Factors that favour the occupation of secondary cavity-nesting species

The numbers of secondary cavity-nesting species we observed varied between colonies. The abundance, richness and occupation of secondary cavity-nesting species was higher at colonies with more Sand Martin pairs. This suggests that aside of the positive effect of creating adequate nesting places (deep burrows, in vertical cliffs, and located far away from the soil surface), the colonies could be providing other factors which could influence secondary cavity-nesting species colonization, such as a direct defence from predators (Brown and Brown 2001). Due to the Sand Martins' gregarious behaviour, the number of individuals guarding and defending the colonies is higher at colonies with more individuals.

The persistence of Sand Martin pairs in a colony is uncertain. Burke (2017) described their dynamic behaviour, observing colonies that were occupied for several consecutive years, colonies that changed their location but remained in the mining site, and mining sites which were completely abandoned. We observed a similar phenomenon, having detected large colonies formed by hundreds of burrows which were abandoned from one year to the next. Bearing in mind that burrowing is energetically a costly activity, the ease with which Sand Martins abandon colonies is, from our point of view, one of the less known aspects of this species, likely linked to their social behaviour and the conspecific attraction for reproduction. Thus, further studies are needed to understand Sand Martin persistence to the colonies in order to improve the management and conservation of this species and its secondary cavity-nesting species.

The number of burrows had a positive effect on the secondary cavity-nesting species abundance, indicating that larger colonies may exert a greater attraction effect over secondary cavity-nesting species. The abundance of Sand Martins was not related to the number of burrows at the colonies or mining sites. Colonies normally have a surplus of burrows due to different reasons, e.g. partially dug burrows, partially collapsed burrows, non-reoccupied burrows, or males constructing more than one burrow in the attempt to attract females (Kuhnen 1985). Sand Martin occupation has been estimated to be 50% at the colony scale (Wright et al. 2011) and our estimations coincide with the literature. This low occupation rate by Sand Martins leaves an elevated number of empty burrows potentially available for secondary cavity-nesting species.

We observed a negative relationship between the age of the structure where the colony was excavated and Rock Sparrow abundance and occupation. This result does not support our original hypothesis that the age of the structure could have a positive effect by increasing the available time for Sand Martins and secondary cavity-nesting species to colonize the structures. However, more recent structures may be easier to excavate by the Sand Martin, due to less compaction of the sandy material. Also, the type of structure was related with the age of the structure and Sand Martin abundance. Stockpiles are formed by homogenous material allowing larger suitable surfaces for excavating in, and since they are more temporary than vertical extraction faces, they do not reach as much longevity. Stockpiles might therefore attract more abundance and occupation of secondary cavity-nesting species. All these variables should be taken into consideration to design measures to increase secondary cavity-nesting species abundance and manage their populations in mining areas.

Implications for mining site restoration

We have found more colonies and burrows in mining sites than previous studies have, which suggests that previous studies underestimate the presence of Sand Martin burrows at mining sites and their potential benefits for other species. This could have relevant conservation implications. Importantly, we found a community of secondary cavity-nesting species using the Sand Martin burrows in mining sites, which matches the species composition of the cavity-nesting community found in non-mining site colonies. Thus, the Sand Martin could be considered an engineer species given its resembles to other burrowing species, such as the European Bee-eater and European rabbit (Casas-Crivillé and Valera 2005; Galvez Bravo et al. 2009; Suvorov et al. 2011).

The advantage of managing for Sand Martins in mining restoration projects has a two-fold effect. On the one hand it serves as an opportunity to benefit this endangered species by promoting its presence and increasing its density, and on the other hand, by allowing the knock-on beneficial effects of this species on the cliff-nesting bird community as follows. Nesting cavity presence frequently limits secondary cavity-nesting species occupation. Our results show that in mining sites the Sand Martin modifies abiotic resources by making nesting cavities secondarily available to other bird species, promoting colonization and potentially increasing bird species richness and biodiversity. Thus, the promotion of Sand Martins in restoration projects could make mining sites less dependent on direct human intervention to maximize biodiversity.

This study has helped us understand the nesting site mediation role that Sand Martins provide for other cavity-nesting species through the transformation of vertical extraction faces. Abiotic engineering activities are possibly the

least studied ecological contribution of birds (Sekercioglu 2006), so future research on the effects and consequences of bird engineering could provide opportunities in mining restoration for potential biodiversity conservation.

ETHICAL STATEMENT

All applicable international, national, and/or institutional guidelines for the care and use of animals were followed. All procedures performed in studies involving animals were in accordance with the ethical standards of the Spanish Ministry of Agriculture, Environment and Food (MITECO) and the Dirección General del Medio Ambiente de la Consejería de Medio Ambiente, Administración Local y Ordenación del Territorio de la Comunidad de Madrid (REF:10/148281.9/17 with date 18/05/2017). Bird manipulation was done by an expert of SEO/Birdlife's the Bird Migration Center and with authorization for Scientific Banding of the Spanish Ministry of Agriculture, Environment and Food (permit number nº 530339). LafargeHolcim Spain granted access to all of the studied mining sites, and all of the security requirements and procedures were complied with.

ACKNOWLEDGEMENTS

This project was financed through a partnership between the International Foundation for the Restoration of Ecosystems (FIRE) and LafargeHolcim Spain, and supported by the Forest Ecology and Restoration Group (FORECO) of the University of Alcalá (UAH). E. Andivia was supported by a postdoctoral grant funded by the Universidad Complutense de Madrid (UCM). We would like to specially acknowledge Pilar Gegúndez and Raúl Pérez for their support. Also, to Manuel Andrés, Rafael Barrientos and Aurelio Malo for their contributions. We declare that this work fully complied with the current Spanish laws.

REFERENCES

- Barton K (2017) MuMIn: Multi-Model Inference. R package version 1.40.0
- Bates D, Maechle M, Bolker B, Walker S (2015) Fitting Linear Mixed-Effects Models using lme4. *Journal of Statistical Software* **67**:1–48
- BirdLife International (2017) *European birds of conservation concern: Populations, trends and national responsibilities*. Cambridge, UK. <https://www.nabu.de/imperia/md/content/nabude/vogelschutz/170520-birds-of-conservation-concern-germany.pdf>. (accessed 8 March 2018)
- Blancat J, Jurado P, Jiménez-moya F (1995) Contribución al conocimiento del abejaruco común *Merops apiaster* en la provincia de Sevilla. *Orsis Organismes i Sistemes* **10**:99–104
- Brown CR, Brown MB (2001) *Current Ornithology, Volume 16*. Springer US, Boston
- Burke T (2017) Bank Swallow (*Riparia riparia*) Breeding in aggregate pits and natural habitats. Dissertation, Trent University <http://digitalcollections.trentu.ca/objects/etd-553>. (accessed 8 March 2018)
- Burnham KP, Anderson DR (2001) *Model selection and multimodel inference. A practical information-theoretic approach*. 2nd ed. Springer, US, New York
- Byers JE, Cuddington K, Jones CG, et al (2006) Using ecosystem engineers to restore ecological systems. *Trends in Ecology & Evolution* **21**:493–500
- Cano Sánchez J (2003) Gorrión Chillón (*Petronia petronia*). Pages 566–567. In: Martí R, Moral J (eds) *Atlas de las aves reproductoras de España*. Dirección General de Conservación de la Naturaleza-SEO, Madrid
- Casas-Crivillé A, Valera F (2005) The European Bee-eater (*Merops apiaster*) as an ecosystem engineer in arid environments. *Journal of Arid Environments* **60**:227–238
- Castillo I, Elorriaga J, Zuberogoitia I, Azkona A, Hidalgo S, Astorkia L, Iraeta A, Ruiz F (2008) Importancia de las canteras sobre las aves rupícolas y problemas derivados de su gestión. *Ardeola* **55**:103–110
- Chiquoine LP, Abella SR, Bowker MA (2016) Rapidly restoring biological soil crusts and ecosystem functions in a severely disturbed desert ecosystem. *Ecological Applications*, **26**:1260–1272
- Cockle KL, Martin K, Drever MC (2010) Supply of tree-holes limits nest density of cavity-nesting birds in primary and logged subtropical Atlantic forest. *Biological Conservation* **143**:2851–2857
- Cordero Tapia PJ (1986) Aspectos de la ecoetología de la nidificación en el gorrión molinero (*Passer m. montanus* (L.)) y el gorrión común (*Passer d. domesticus*, (L.)) en Cataluña. PhD Thesis, Universitat de Barcelona. <http://diposit.ub.edu/dspace/handle/2445/35931>. (accessed October 2018)
- Cramp S (1988) *Handbook of the birds of Europe, the Middle East and North Africa. The birds of the Western Palearctic*. Oxford University Press, Oxford, United Kingdom
- Galvez Bravo L, Belliure J, Rebollo S (2009) European rabbits as ecosystem engineers: Warrens increase lizard density and diversity. *Biodiversity and Conservation* **18**:869–885
- García J, Álvarez E (2000) Expansión altitudinal del avión zapador *Riparia riparia* en la Cordillera Cantábrica. *Ardeola* **47**(2):247–250
- González S, Villarino A (1997) Nidotópica y situación actual del Avión Zapador *Riparia riparia* (L. 1758), en la Provincia de Ourense (NO España). *Ardeola* **44**:41–49
- Hansell MH (1993) The ecological impact of animal nests and burrows. *Functional Ecology* **7**:5
- Hjertaas DG (1984) Colony Site Selection in Bank Swallows. PhD Thesis, University of Saskatchewan <https://core.ac.uk/download/pdf/55300816.pdf>. (accessed 3 March 2018)
- Jones CG, Lawton JH, Shachak M (1994) Organisms as ecosystem engineers. *Oikos* **69**:373–386
- Kuhnen K (1985) Zur Paarbildung der Uferschwalbe (*Riparia riparia*). *Journal of Ornithology* **126**:1–13
- Madroño A, González C, Atienza JC (2004) *Libro Rojo de las Aves de España*. Dirección General para la Biodiversidad-SEO / Birdlife. Madrid
- Manning A, Wood J, Cunningham R, McIntyre S, Gordon I, and Lindenmayer D (2011) Integrating research and restoration: the establishment of a long-term woodland experiment in south-eastern Australia. *Australian Zoologist*, **35**:633–648
- Mead CJ, Pepler (1975) Birds and other animals at Sand Martin colonies. *British Birds* **68**:89–99.
- Piotrowski S, Evans S, Walshe J (2011) *Suffolk Tree Sparrow Project 2008-2011*. <http://citeseerx.ist.psu.edu/viewdoc/download?doi=10.1.1.737.2559&rep=rep1&type=pdf>

(accessed 23 November 2018)

- R Core Team (2017) *R: A language and environment for statistical computing*. R Foundation for Statistical Computing, Vienna
- Sekercioglu C (2006) Increasing awareness of avian ecological function. *Trends in Ecology and Evolution* **21**:464–471
- Soler M (2014) Grajilla – *Corvus monedula* Linnaeus, 1758. In: Salvador A, Morales MB (eds) *Enciclopedia Virtual de los Vertebrados Españoles*. Museo Nacional de Ciencias Naturales, Madrid
- Suvorov P, Kovář V, Heneberg P (2011) Use of a new breeding habitat is associated with Sand Martin (*Riparia riparia*) mixed colonies. *Sylvia* **47**:49–66
- Wenny DG, DeVault TL, Johnson MD, Kelly D, Sekercioglu C, Tomback DF, Whelan CJ (2011) The need to quantify ecosystem services provided by birds. *The Auk* **128**:1–14
- Whelan CJ, Wenny DG, Marquis RJ (2008) Ecosystem services provided by birds. *Annals of the New York Academy of Science* **1134**:25–60
- Wright DH, Lomeli H, Hofmann PS, Nguyen C (2011) Burrow occupancy and nesting phenology of bank swallows along the Sacramento river. *California Fish and Game* **97**(3):138–147





CHAPTER VI

General Discussion

CHAPTER VI

General Discussion

This study focused on the ecology of the cliff-nesting birds that breed in mining sites in Spanish Mediterranean areas, with the objective of setting management recommendations for these species at active and inactive mining sites (Figure 6.1). We first studied the cliff-nesting communities at a national scale to determine their general characteristics and to identify general processes that could condition the management recommendations of these cliff-nesting bird communities (Chapter II). To further explore these general processes, we focused on two model species, and we designed species-specific studies. Then, we studied the risks of creating ecological traps due to predation excess by the territorial Eagle Owl (Chapter III). We studied the breeding habitat selection and preferences at different spatial scales for the

colonial Sand Martin (Chapter IV). Finally, we studied the engineering activities of the Sand Martins (Chapter V). This last study allowed us to explore the ecosystem services that burrowing cliff-nesting birds provide at mining sites, and whether these engineering activities could be taken advantage of in mining restorations to promote biodiversity at mining sites. The results of these four research studies gave us insight to outline management recommendations for cliff-nesting birds, both to reconcile their presence at active mining sites and to propose mining restoration actions to promote local biodiversity through these species (Figure 6.1).

Regarding the study of the cliff-nesting communities (Chapter II), we found a considerable species abundance and richness of

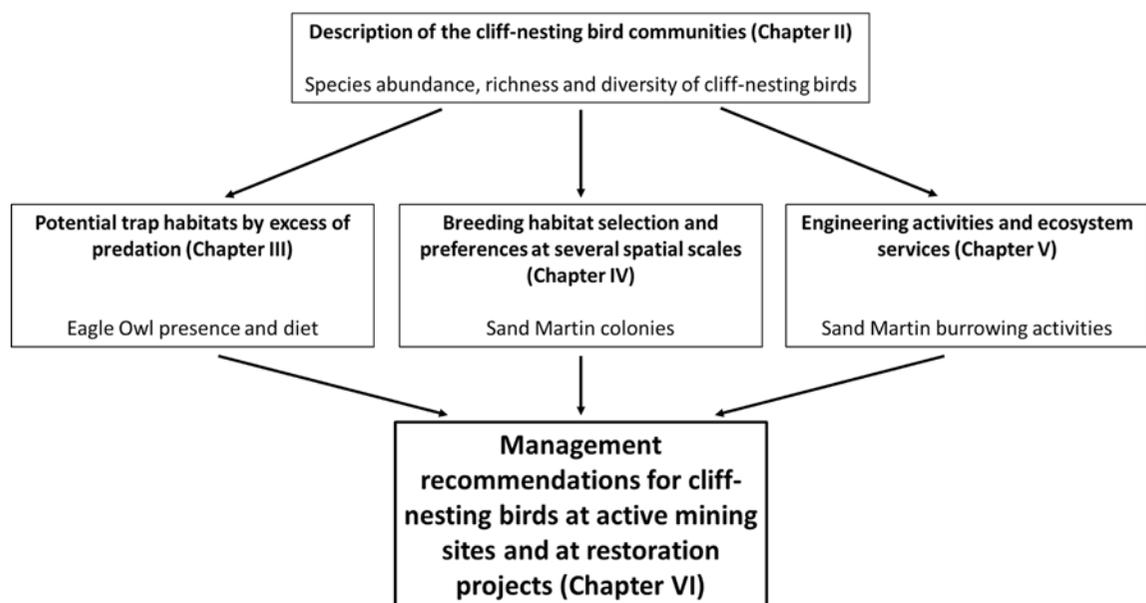

Figure 6.1 Conceptual diagram of the relationships between the four research chapters which studied different aspects of cliff-nesting birds at mining sites.

cliff-nesting birds in the mining sites. We found a range of groups, from large raptors such as the Eagle Owl to Passerines like the Rock Sparrow. As far as we know, previous work did not address the complete communities colonizing mining sites, and was centered on specific species or groups (e.g. Boyce et al. 1980 ; Norriss 1995; Brambilla et al. 2010; Ostlyngen et al. 2011). We also observed the importance that these man-made habitats can have for some species, namely the Sand Martin (Chapter IV), for which we were unable to locate relevant breeding colonies in natural habitats outside the mining areas. This could mean that mining sites are even more relevant as breeding habitats for some cliff-nesting species than we expected, stressing the need for managing these species during the active phases of the mining sites. Furthermore, our findings support that actions to promote habitat enhancement for cliff-nesting birds could be an interesting option in mining restoration (Castillo et al. 2008).

Criteria for successful habitat restoration and management for cliff-nesting birds

Hale & Swearer (2017) outline five criteria to ensure restoration provides suitable habitats for animals (Figure 6.2). This diagram is a useful guide for restoration and management plans for animals, which we use here to place our study into greater perspective.

This diagram orders five criteria in a hierarchical flow that allows us to analyze the potential constraints to successful habitat restoration for cliff-nesting birds at mining sites. The first point (point 1, Figure 6.2) is that restoration must improve structural habitat. Restoration is commonly undertaken on the assumption that animals will respond to improvements in structural habitat (Palmer et al. 1997). We can assume that mining activity improved structural cliff habitats for the local cliff-nesting community

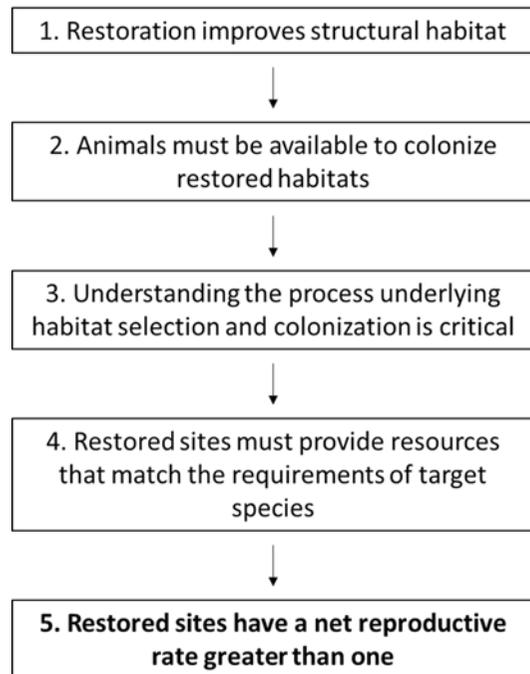

Figure 6.2 Five criteria for ensuring habitat restoration and management for cliff-nesting birds is successful (based on Hale & Swearer 2017).

because we found that many mining sites did not have relevant natural cliff habitats in the surroundings. This could explain, at least partially, the relative abundance, richness and diversity of cliff-nesting birds in the cliff habitats of the studied mining sites.

Once the habitat is present, for successful habitat restoration to occur, animals must be available to colonize these areas (point 2, Figure 6.2). The proximity of source populations to restored sites is an important factor to determine restoration success (Sunderman et al. 2011). We confirmed the influence of this factor in Chapter IV by detecting a positive effect of the regional pool of Sand Martins, and a negative effect of the distance of the mining sites to natural riparian habitats in the colonization of mining sites by Sand Martins. In general, we expect birds to have less dispersal limitations than other taxonomic groups (e.g. mammals, reptiles or amphibians). However, the presence

of the target species in the proximity of the restored habitats should be a fundamental guide for habitat restoration decisions. A mixture of landscape-level characteristics (e.g. size, shape, and location of restored habitats, distance to sources, connectivity, matrix characteristics, barriers to colonization) and animal life-history traits (e.g. dispersal ability) are likely to determine encounter rates of the cliff-nesting birds with the restored mining sites, and they should be explored in future researches.

Once the target species is present near the restored habitat, to obtain populations with reproductive success we need to understand their underlying habitat selection and colonization processes in order to attract the target species to the restored sites (point 3, Figure 6.2). The Sand Martin was an effective model species to study the habitat selection process and habitat preference at several scales, the relevance of mining sites as breeding habitats for burrowing cliff-nesting species, and to help establish management recommendations for burrowing birds (Chapter IV). However, the knowledge of habitat preferences at several scales is not enough to understand the habitat selection and colonization processes. Many colonial birds use social cues (e.g. bird calls of reproductive adults or chicks in different stages of development) to select habitats, and appropriate but unoccupied habitats can be colonized when social cues are added (e.g., vocalizations) (Danchin & Wagner 1998).

In this sense, we explored the use of artificial nests to attract Sand Martins in complementary projects related with this study. The sandy substrates where they find their nesting habitats are more malleable and involve fewer risks than rocky substrates, which allowed us to experiment with designs to accommodate Sand Martins in mining sites, as we detail in section a.2. Furthermore, the results of our study allowed us to edit guidelines for best management

practices for this species in aggregate sites in Mediterranean areas (Rohrer et al. 2018), but which can be extrapolated to all of Europe by taking into account the regional variations of the species. We believe that this type of documents uniting scientific research with practice are lacking. This was confirmed by the good acceptance the guidelines had in the industry, to the point that the National Aggregate Federation (Federación de Áridos) in Spain promoted it in the sector at national level, and encouraged companies to voluntarily join an agreement aimed at promoting and coordinating actions to reconcile Sand Martins with the aggregate industry.

In contrast to colonial species, the colonization of the restored sites by territorial cliff nesting species, such as the Eagle Owl, will depend on the distance to other active nests, located inside or outside the mining sites (nearest neighbor distance).

Once we attract the target species to the restored habitat, the next factor that constrains population growth is the provision of resources that match the requirements of target species (point 4, Figure 6.2), such as requirements for breeding, food, shelter, roosting, etc. In our study we focused on the nesting sites in the cliff habitats and future research will be necessary to study the rest of the ecological requirements of these species and the habitats that can provide them. Therefore, apart from providing nesting structures, introducing foraging habitats at the mining sites should be simultaneously considered during management and restoration activities (section c). Including these habitats in restoration plans would increase spatial heterogeneity and promote not only cliff-nesting species, but also many other varied taxa. Our results also suggest that the surroundings of the mining sites seemed to be important for the cliff-nesting birds because the home range of the studied bird species usually exceed the dimensions of the mining sites (Chapters III and

IV). The main hunting areas for Eagle Owls were probably outside the mining sites (Chapter II) and Sand Martins selected mining sites closer to habitats that could provide food, such as water bodies (Chapter IV).

Related with point 4 (Figure 6.2), the suitability of habitats for specific species may also change over time following restoration, because the availability of resources can change (Hale & Swearer 2017). For example, the conditions of the cliff faces changes with time, due to erosion and weathering. One of the decisions that will need to be considered in the design of nesting structures in restored areas is whether they will be temporary or permanent. According to this, the design will be different in terms of effort and costs.

Taking into account the trophic information of the bird species provided by Salvador & Morales (2002), the studied cliff-nesting communities were formed predominantly by granivorous and insectivorous birds. Therefore, a relevant feature for these species in the surroundings of the mining sites could be agricultural and grassland habitats which provide their food. These open habitats would also provide hunting grounds for some raptors (Marchesi et al. 2002; Sergio et al. 2004). This coincides with our observations, where the mining sites surrounded by forests habitats were the ones with less cliff-nesting species abundance and richness.

It is important to note that meeting this criterion (point 4: provide resources that match the requirements of the species) will result in intended and unintended interactions with other species. For example, attraction of predators and secondary users of Sand Martin burrows may have expected as well as unwanted consequences for the target species and for local biodiversity. Studying the presence and diet of the Eagle Owl taught us first that Eagle Owls are frequently found in mining sites in Mediterranean areas. Second, that this

top predator specialized in the consumption of rabbits (Penteriani et al. 2005), and did not seem to constitute an ecological trap for the cliff-nesting birds in our study area (Chapter III). Nonetheless, taking into account possible hidden risks resulting from restoration projects that could generate ecological interactions for the colonizing fauna should have a higher relevance when monitoring the projects' outcomes (Hale & Swearer 2017).

The final point of Hale & Swearer's (2017) diagram emphasizes that the final goal of any restoration plan for animals is a net reproductive rate, that is similar or greater in restored sites than in not restored ones, in order to obtain viable animal populations (point 5, Figure 6.2). The key question is the degree to which restoration increases productivity (population growth of a target species) or simply attracts individuals from elsewhere. We tried to confirm the reproductive success of the two model species and the secondary users of Sand Martin burrows in our study (Chapters III, IV and V). Monitoring the reproduction of the colonizing populations should be essential to determine the success of the restoration projects. Further studies that analyze the reproductive success of cliff-nesting birds at mining sites and compare them with populations at natural habitats, should be the next steps to determine whether the restoration measures are favorable for these species. Moreover, to be able to study in depth whether Eagle Owls generate ecological traps, further studies are needed to address the preferences and fitness of the cliff-nesting birds sharing habitat with this top predator. For instance, by comparing preferences and reproductive success in mining sites with and without Eagle Owls, or by comparing preferences and breeding populations at mining sites with populations at natural habitats.

With the secondary users of Sand Martin burrows we also explored bird services that

could be used to design more passive and self-regulating restorations and biodiversity management practices (Chapter V). Though the size of the Sand Martin burrows determines that only birds of a small size can benefit from their burrowing activity, we found that a range of birds can colonize these burrows in the mining sites, as they do in natural habitats. How to make burrows and holes available for larger species should be studied further. Moreover, other ecosystem functions and services of birds applied for restoration should be explored further, such as seed dispersal, the disturbing effects on the soil and sandy cliffs, or enriching local topsoils and promoting plant growth (Fedriani et al. 2015). All of these bird services can be very useful in restorations, making them less costly and less dependent on direct human intervention to maximize biodiversity. Finally, when promoting the prey of the cliff-nesting raptors that colonize the mining sites, such as rabbits for the Eagle Owls, we would in fact be promoting ecosystem engineers (Gálvez-Bravo et al. 2008) that can provide many other services in restored sites as well. By using cliff-nesting birds as target species we would be not only promoting these species, many of which have conservation status in different areas of their distribution, but also other species and ecosystem services would be promoted as well.

Restoration and management recommendations for nesting structures on cliff environments

To the best of our knowledge, restoration and management recommendations for cliff-nesting birds at mining sites are greatly lacking, both for active and inactive mining sites. In this section we propose some initial and basic general guidelines with the aim of promoting habitat improvement actions at mining sites using cliff-nesting species as target species. For this, we summarize our findings and experience, and general recommendations

from the literature. The recommendations are divided between restoration actions at inactive sites and management actions at active sites, and between rocky and sandy substrates.

Regarding the design of restoration projects, each mining site will present its own unique set of opportunities, advantages and disadvantages, and should be assessed on a case-by-case basis to design the most adapted actions for each scenario. The level of complexity and cost of the actions can vary from simple low-cost designs, such as increasing the verticality of a slope, to complex expensive ones, such as constructing nesting colonies of concrete. This will depend on the desired persistence of the actions (temporary or permanent), the amount of monitoring of the individuals colonizing the structure, and of course, the objectives and available budget.

All of the restoration and management actions carried out at mining sites should be accompanied by awareness creation of the staff and local stakeholders. Promoting awareness regarding the species that are being promoted and informing the staff of the measures taken and their location are essential to ensure the success of the actions carried out. Also, counting with the support of local stakeholders will help to ensure the acceptance and success of the projects as well.

a) Restoration recommendations for inactive mining sites

a.1) Restoration recommendations for rocky substrates

Regarding cliff-nesting birds that breed on rocky cliffs, their presence could be promoted by maintaining tall vertical cliffs with holes adapted to their various sizes and requirements, especially at those cliffs that had already been colonized. The dimensions of the cliffs and holes will determine the range of species that will be able to breed there.

Increasing the available nesting holes can be achieved by selective blasting and drilling (Pagel 1989; CEMA (Fundación Laboral del Cemento y el Medio Ambiente) 2010). These actions should be carried out in the upper third of the cliffs and the dimensions and depths of the holes will vary to accommodate different species. It would also be advisable to enable ledges of ample surfaces for larger species to perch (e.g. around 2 x 1.5 m), such as Eagle Owls or Peregrine Falcons (Penteriani & Delgado 2016; Zuberogoitia 2016). Overhead protection on the ledges could be advisable to increase shelter and provide safety from predators such as the Eagle Owl, but they should be high enough so that they do not impede the use of the ledge or cavity.

For those situations where it is not possible to carry out blasting, there are examples where

nest boxes have been very successful for some species, the Peregrine Falcon (Boyce et al. 1980), the Common and Lesser Kestrels and nocturnal raptors (CEMA 2010; Brinzal 2018) among them. The nest boxes should also be located in the upper third of the walls, and the size of the boxes and their characteristics will vary according to the species we wish to attract.

There is a rather strong debate on whether to allow rocky cliff environments to remain in mining sites, since this goes against the basic and extended idea that mining sites should be refilled (Figure 6.3), and also because there is always the question of stability and safety. However, there are techniques that allow safe cliffs of certain heights to remain (Figure 6.4). Even if they do not reach great heights, these cliffs could still fulfill many species' nesting habitat requirements.



Figure 6.3 Example of a restoration that involved decreasing slopes by refilling with material.



Figure 6.4 Examples of restored sections of a mining site that maintained vertical rocky cliffs, though without the objective of attracting birds.

Another approach that produces stable vertical rocky cliffs is the Talud Royal@ technique (Figure 6.5). This method consists on selecting a reference ecosystem from the surrounding landscapes formed by the same rocks as the mining site, and analyzing their geomorphological evolution. This geological study includes aspects such as detecting the main lines of discontinuity of the rock mass which generate instability, and understanding the patterns of that instability, such as the erosive processes and their occurrence. Then, these responses are imitated with the aim of accelerating the geomorphological evolution and weathering processes that would act spontaneously over time on the restored cliffs. This is achieved through selective blasting and detailed clearing of unstable blocks with a backhoe, and even manually. The result is a very stable slope, visually integrated into the environment, with maximum ecological advantages, and with very low maintenance requirements since it avoids erosion problems (Martín Duque et al. 2011).

a.2) Restoration recommendations for sandy substrates

Another option could be to design actions towards sandy substrates, especially in the aggregate sector. Restoration actions could be directed at maintaining vertical structures where

Sand Martin or European Bee-eater colonies had previously been located (by repairing or enhancing old structures with colonies) or designating new potential nesting sites. Opposite to rocky substrates, actions on sandy substrates can be temporary, the same way natural vertical banks on rivers are dynamic structures.

The materials used in these projects should be compact enough so that the structure does not collapse, but with a grain small enough to allow burrowing. The recommended grain in the literature varies, but grains between 2-6 mm have been successful (Heneberg 2001; Bachmann et al. 2008). Burrows are mostly located in the highest sections of the structures to avoid predation. Therefore, the vertical surfaces should be 4-6 m high, to protect against predation and other risks (Szép et al. 2016). Slopes should be maintained at least at 70° and tall vegetation should be eliminated in the surroundings of the vertical face, to allow easy access to the birds. Also, the fallen material at the base of the vertical face (talus) should be removed to avoid access to predators (Mead 1979; Heneberg 2013). The location should be far from mining activity and other disturbances (Ye et al. 2016), near water sources with high insect production, orientated to the Southwest if possible, and to open areas to allow easy access to the colony (OMNRF 2017).

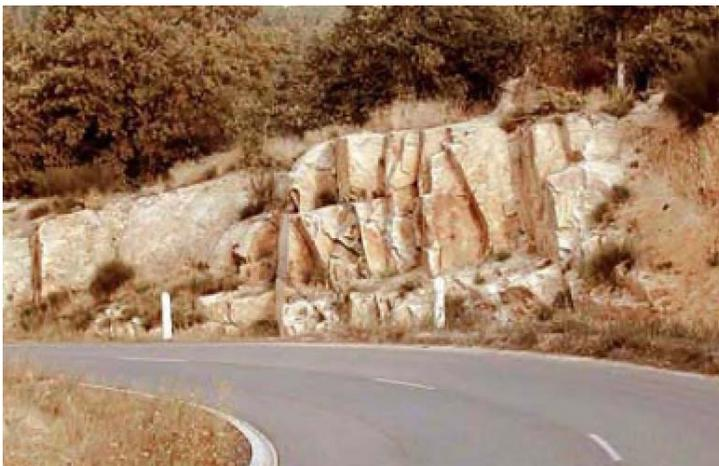

Figure 6.5 Recently formed cliff treated with the Talud Royal@ technique on the road RD 105, Loire (France), in which the exposure of surfaces already show a weathered appearance (Martín Duque et al. 2011).



Figure 6.6 Sandy vertical cliff in 2016 with a large Sand Martin colony at a restored aggregate pit in Madrid (Spain).

In 2016 we monitored a successful case where a Sand Martin colony colonized a vertical face that was prepared following these recommendations. This design was temporary, and it imitated a sandy cliff, similar to what river erosion might produce at a sandy bank (Figure 6.6).

Based on this experience, we designed another sandy cliff. In this example (Figure 6.7), the cliff is formed by a stockpile of compacted material, with two layers. In the center, a 2-meter layer of sand and lime to give consistency and where the Sand Martins would nest. The lower layer is formed by gravel to create a platform to lift the nesting area and protect it from predators, and the upper layer as well, to protect the sand from erosion. It is located facing a pond. We will improve the capacity to attract individuals

to the artificial colony with artificial nests or vocalizations. The objective of this action is to create a Sand Martin breeding habitat in an area where Sand Martin presence has been observed but no suitable cliffs are present (Diaz Rojas et al. 2018).

According to the restoration objectives, permanent nests can also be installed by constructing colonies with nest boxes. These can allow detailed studies of the Sand Martin, such as their reproductive biology. There is only one case in Spain (Álava) that we are aware of, where one of these permanent structures has been very successful. One of the reasons could be because they used Sand Martin vocalizations to attract the first individuals to the artificial colony (Bea et al. 2011). Based on our experience and after visiting this successful case, we proposed a permanent colony together with the NGO Brinzal, which is included in a mining restoration plan in Madrid. The design (Figure 6.8) consists on different units formed by a metal structure with wooden shelves, on which are wooden nest boxes designed for Sand Martins. The rectangular structure that protects the units can be built with solid wood or concrete, it has a door to access the interior, and a small window protected with a mesh in the upper part to improve the visibility inside the structure and allow ventilation. This design is aimed at providing a new colony in an area where several

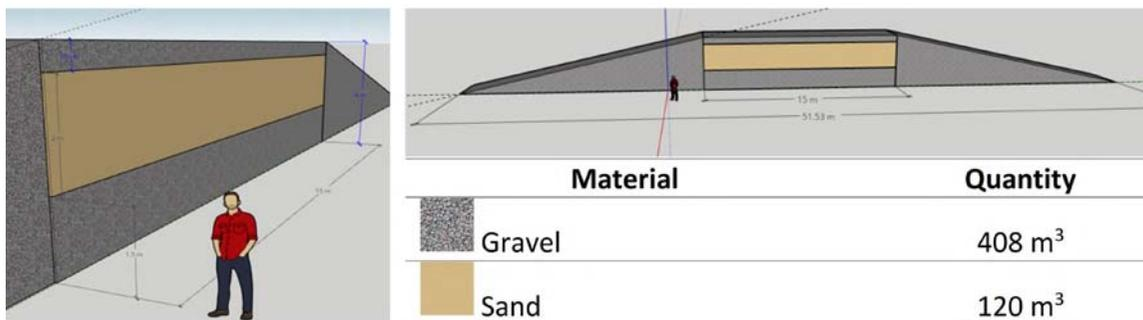

Figure 6.7 Example of a temporary design for a restoration project. The objective was to promote Sand Martin presence in an area where Sand Martin presence had been observed but no suitable cliffs were available.

Sand Martin colonies had been occupied for at least two years and individuals are still currently present (Diaz Rojas et al. 2018).

Both examples (Figures 6.7 and 6.8) were designed based on the findings of our studies and a thorough review of best practices carried out internationally, and will be carried out shortly in two restoration projects in Madrid.

b) Management recommendations for active mining sites

b.1) Management recommendations for rocky substrates

Many of the proposed actions in section a.1 are also applicable for management in active mining sites. Nest boxes on cliffs or buildings could be located in areas that would interfere the least with mining activity and which would be less disruptive for the birds. These locations could

change with the evolution of the extraction of the mining site, and this can apply as well to other habitats at mining sites that provide other requirements for the target species, such as spontaneously formed ponds (see section c).

b.2) Management recommendations for sandy substrates

Management actions should be based on avoiding bird presence in active areas of the mining sites and promoting them in inactive areas. To do this, actions should be based around an annual calendar that takes into account the yearly mining activities and the regional migration and breeding phenology of the target species, mainly Sand Martins. At active areas, colonization of cliffs and stockpiles should be deterred during spring and summer by decreasing slopes (<60°). If colonization does take place, the mining activity should cease until September, and protection

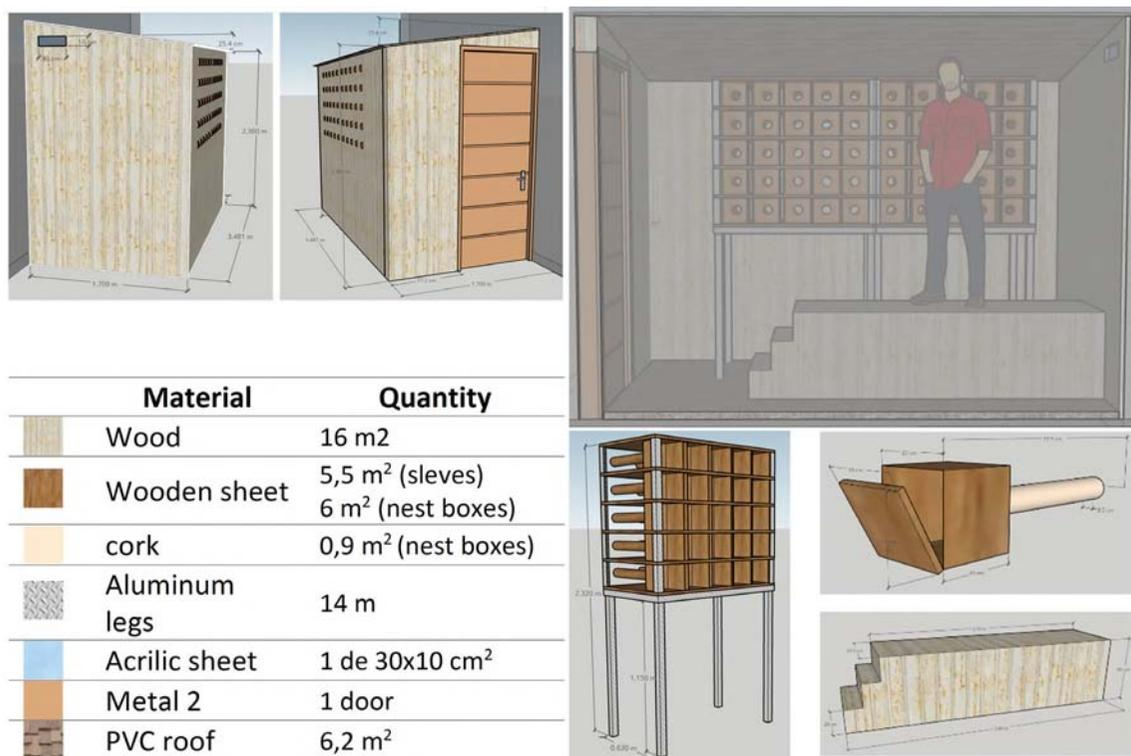

Figure 6.8 Example of a permanent design for a restoration project. The objective was to promote Sand Martin presence in an area where Sand Martin colonies had been active for at least two years.

barriers and warning signs around the colony should be placed. At inactive areas, the species can be promoted, by preparing suitable habitats at the end of winter or at the beginning of spring. These should be protected and monitored in the spring and summer.

The colonies should have a southwest orientation and avoid flight obstacles. They should be located near water or other habitats with high insect production, and far from disturbances (mining and people). The material should allow burrowing but be compact enough not to collapse (granulometry 0-6 mm). Approximate recommended dimensions are 4-6 m high and 5-10 m long and with a 90° slope.

Maintenance of these structures is possible at active mining sites, which could extend the persistence of the colonies. The literature recommends cutting the face with a backhoe to keep it vertical, leave some previous burrows which will serve the purpose of attracting conspecifics, and eliminate talus and tall vegetation to avoid access to predators and flight obstacles every two years. Maintenance of the protection barriers would also be recommended (Figure 6.9).

c) Restoration and management recommendations for complementary habitats

As we mentioned in the section *Criteria for successful habitat restoration and management for cliff-nesting birds*, we need to provide the resources so that the colonizing species reach a positive reproduction rate. Taking advantage of other habitats that appear in the mining sites spontaneously, and which are often undervalued, could help maintain biodiversity in the area, and they should be managed accordingly. For example, there are many inactive areas in the mining sites that might contribute to this purpose, such as a security perimeter that is often found of around the mining site, where management actions favoring temporary ponds, ruderal patches with seed producing herbaceous plants or maintaining spontaneous shrubs could be beneficial for many species.

Ruderal grasslands with native seed banks, such as thistle or thyme fields (Figure 6.10 a, b), shallow or deep ponds (Figure 6.10 c, d) or mounds of discarded rock and topsoil (Figure 6.10 e, f) could be managed both in the safety perimeters around the mining sites and in the

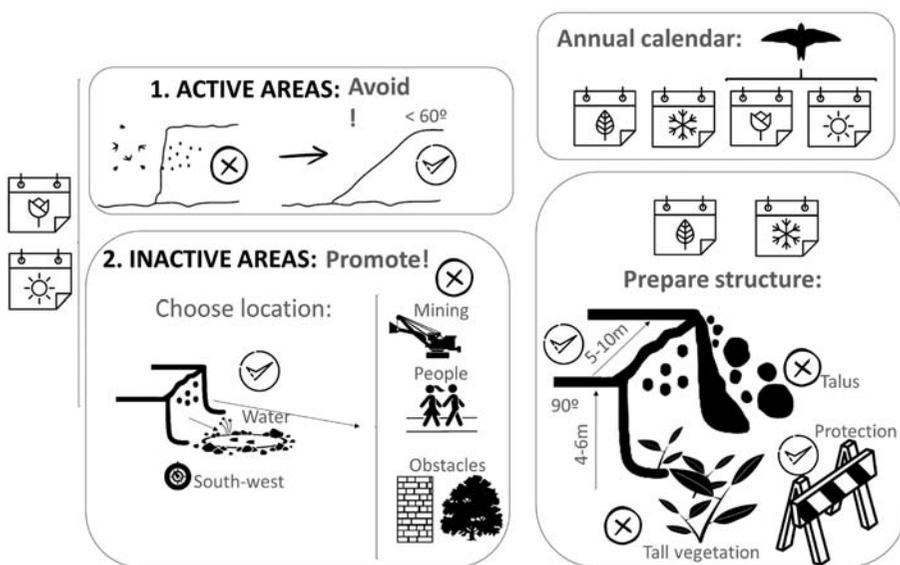

Figure 6.9 Summary of management actions for sandy substrates at active mining sites.

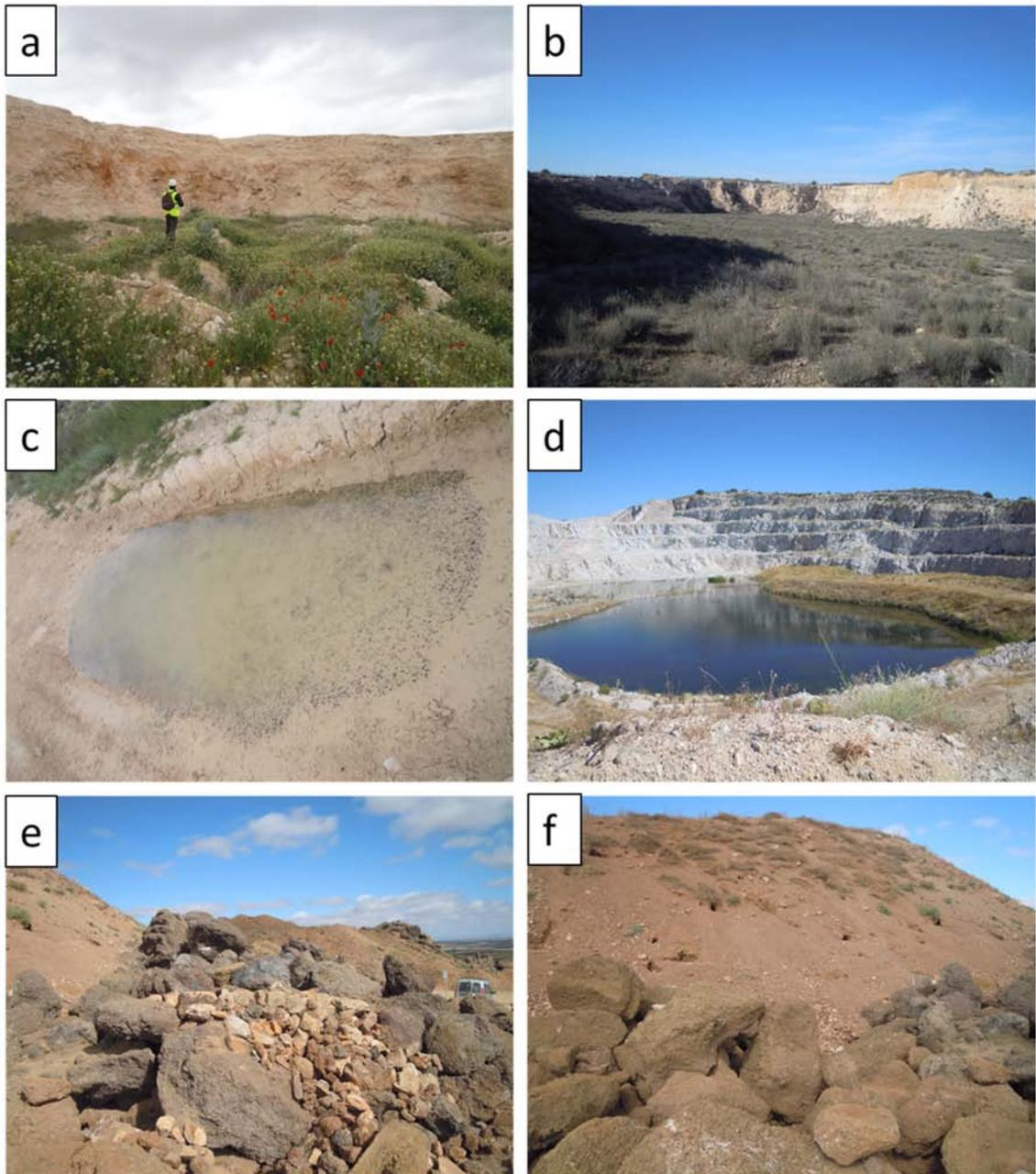

Figure 6.10 a) area where ruderal vegetation and b) thyme fields have spontaneously appeared at inactive areas of mining sites; c) shallow pond with tadpoles; d) deeper pond which also appeared spontaneously; e) rocky mound of discarded material where different Wheatears and rabbits thrived; f) large rabbit colony settled in a mound of topsoil.

mining sites themselves. As the nest boxes in section b, they could be maintained if they do not interfere with mining activity and then be relocated when industrial activity advanced. Ruderal strips around the perimeter or areas within the site that have already been restored could be allowed to grow, and reinforce seed producing of the herbaceous plants.

Restoration and management recommendations for hunting areas for Eagle Owls

One of the cliff-nesting birds that colonized mining sites frequently was the Eagle Owl, a generalist top predator. However, the Eagle Owl's diet in the mining sites and the abundance of cliff-nesting birds in presence of this species suggest that this predator is not an important limitation for cliff-nesting bird colonization of the mining sites (Chapter III). However, taking precautions to avoid generating trap habitats should not be ignored when designing restoration projects (Hale & Swearer 2017).

Rabbits were the Eagle Owl's main prey. Therefore, the promotion of rabbits in the mining sites and their surroundings could help prevent an excess of predation on cliff-nesting birds. It is not the objective of this work to study in depth the rabbit populations or how to manage this species in the mining sites. However, carrying out

integrative and global actions, which take into account not only the cliff environments but all kinds of environments in the mining sites, should be considered simultaneously. Including habitats that are needed to cover the requirements of the target species will also benefit many other species and contribute with many other necessary ecosystem services, such as grasslands that also serve to capture carbon, habitats for erosion control, ruderal areas with food plants for insects, etc. Moreover, promoting rabbits is a way of promoting an ecosystem engineer that will provide other services and advantages to the restored sites.

Regarding the actions to promote the hunting grounds for the Eagle Owl, measures could be adopted to favor the abundance of rabbits in the mining sites. In fact, we observed that the sampling points with a higher rabbit abundance index coincided with restored areas. However, rabbits did not respond equally to all restoration actions, and preferred those that presented heterogeneous environments, with undulated terrain and mounds, and that had different types of herbaceous and shrubby vegetation (Figure 6.11). Environments with these characteristics would offer availability of food and shelter for the rabbits and would favor their populations in the mining sites. The revegetation of the area with shrub species that act as a refuge for the



Figure 6.11 a) and b) Restored areas at mining sites which attracted rabbit population, and which include undulated terrain with shrublands and herbaceous vegetation. c) Rabbit warren formed by piled stones.

rabbits, and grasses and legumes that serve as food, would also be adequate. The species' selection should be planned taking into account the rabbits' requirements, but without forgetting other environmental criteria of revegetation performances (avoiding introduction of invasive species, considering the origin of the individuals, etc.). In addition, water points could be established through artificial or non-artificial ponds. These possibly have more relevance in arid Mediterranean areas.

Finally, building artificial rabbit warrens in the mining sites or their perimeter could also favor rabbit colonization. This technique is one of the most used for the promotion of rabbits, since it provides shelter and a breeding place, and in the context of mining sites, where rocks are readily available, the construction of these structures could be carried out easily. Mainly piles of stones and large rocks that form structures with elevated densities of holes and galleries where rabbits can install their warrens.

Immediate future studies

Chapter II was presented as a descriptive chapter in this PhD Thesis. However, our intention is to transform that chapter in a research article by including the analysis of the drivers of the cliff-nesting community parameters (total abundance and species richness and diversity of cliff-nesting birds). We will explore the relative role of the characteristics of the mining site *sensu strictum* and the surroundings (e.g. 1 Km buffer) in determining community parameters. We think that mining sites are important providing suitable cliff-nesting structures while surrounding areas are important providing the main feeding habitats. Thus, we expect the characteristics of the surroundings will be key to understand the cliff-nesting bird communities at the mining sites.

REFERENCES

- Bachmann S, Haller B, Lötscher R, Rehsteiner U, Spaar R, Vogel C (2008) *Guide de promotion de l'hirondelle de rivage en Suisse. Conseils pratiques pour la gestion des colonies dans les carrières et la construction de parois de nidification*. Fondation Paysage et Gravier, Uttigen, Association Suisse de l'industrie des Graviers et du Béton, Berne, Association Suisse pour la Protection des Oiseaux ASPO/BirdLife Suisse, Cudrefin, Station ornithologique suisse, Sempach, Switzerland. https://www.landschaftundkies.ch/cvfs/4754366/VFS-DFA-1268597-leitfaden_uferschwalbe_fr.pdf (accessed 4 February 2017)
- Bea A, Ruiz De Azua N, Valenzuela M, Fernández JM, Carreras. (2011) Colonias artificiales para favorecer la nidificación del avión zapador. *Quercus*, **303**:15-21
- Boyce A, Fisher L, Lehman WE, Hipp B, Peterson J (1980) Prairie falcons nest on an artificial ledge. *Raptor Research* **14**:46–50
- Brambilla M, Bassi E, Ceci C, Ruboloni D (2010) Environmental factors affecting patterns of distribution and co-occurrence of two competing raptor species. *Ibis* **152**:310–322
- Brinjal (2018) *Hacking, una técnica por la que se han liberado más de 10 crías de lechuza común*. LafargeHolcim, Spain. <https://www.lafargeholcim.es/hacking-una-tecnica-por-la-que-se-han-liberado-mas-de-10-crias-de-lechuza-comun-0> (accessed 18 May 2019)
- Castillo I, Elorriaga J, Zuberogoitia I, Azkona A, Hidalgo S, Astorkia L, Iraeta A, Ruiz F (2008) Importancia de las canteras sobre las aves rupícolas y problemas derivados de su gestión. *Ardeola* **55**:103–110
- CEMA (Fundación Laboral del Cemento y el Medio Ambiente) (2010) *Manual de restauración de la biodiversidad en entornos calizos*. Fundación Laboral del Cemento y el Medio Ambiente, Madrid, Spain. https://www.fundacioncema.org/wp-content/uploads/2017/08/Manual_Restauraci%C3%B3n-de-la-biodiversidad-en-entornos-calizos-REBECA_F.CEMA_.pdf (accessed 18 May 2019)
- Danchin E, Wagner R (1998) The evolution of coloniality: the emergence of new perspectives. *TREE* **12**:342–347
- Diaz Rojas JM, Rebollo S, Rohrer Z (2018) *Mejora del hábitat de nidificación del avión zapador (Riparia riparia) en espacios mineros: Seguimiento y diseño de actuaciones*.

- Master in Restoration of Ecosystems. Postgraduate Program, Universidad de Alcalá, Alcalá de Henares, Spain.
- Fedriani JM, Garrote PJ, Delgado MdM, Penteriani V (2015) Subtle gardeners: Inland predators enrich local topsoils and enhance plant growth. *PLoS ONE* **10**(9):e0138273
- Gálvez-Bravo L, Belliure J, Rebollo S (2008) European rabbits as ecosystem engineers: Warrens increase lizard density and diversity. *Biodiversity and Conservation* **18**:869–885
- Hale R, Swearer SE (2017) When good animals love bad restored habitats: How maladaptive habitat selection can constrain restoration. *Journal of Applied Ecology* **54**:1478–1486
- Heneberg P (2001) Size of sand grains as a significant factor affecting the nesting of bank swallows (*Riparia riparia*). *Biologia* **56**:205–210
- Heneberg P (2013) Decision making in burrowing birds: Sediment properties in conflict with biological variables. *Quaternary International* **296**:227–230
- Marchesi L, Sergio F, Pedrini P (2002) Costs and benefits of breeding in human-altered landscapes for the Eagle Owl *Bubo bubo*. *Ibis* **144**:E164–E177
- Martín Duque JF, de Alba S, Barbero F (2011) Consideraciones geomorfológicas e hidrológicas. pp. 44–72. In: Valladares F, Balaguer L, Mola I, Escudero A & Alfaya V (eds). *Consideraciones geomorfológicas e hidrológicas. In: Restauración ecológica de áreas afectadas por infraestructuras de transporte. Bases científicas para soluciones técnicas*. Fundación Biodiversidad, Madrid, Spain. https://fundacion-biodiversidad.es/sites/default/files/libro_restauracion_ecologica.pdf (accessed 18 May 2019)
- Mead CJ (1979) Mortality and causes of death in British Sand Martins. *Bird Study* **26**:107–112
- Norriss DW (1995) The 1991 survey and weather impacts on the peregrine Falco peregrinus breeding population in the republic of Ireland. *Bird Study* **42**:20–30
- OMNRF (Ontario Ministry of Natural Resources and Forestry) (2017) Best Management Practices for the Protection, Creation and Maintenance of Bank Swallow Habitat in Ontario. Queen's Printer for Ontario, Ontario, Canada. <https://www.ossqa.com/multimedia/2017-03-27-100504-95129/bansbmpenpdffinal.1.117mar17.pdf> (accessed 24 October 2017)
- Ostlyngen A, Johansen K, Halvorsen P (2011) Artificial nests - A remedial action in maintaining viable Gyrfalcon populations? Pages 349–362. In: Watson RT, Cade TJ, Fuller M, Hunt G, Potapov E (eds). *Gyrfalcons and Ptarmigan in a Changing World*, Vol. II. The Peregrine Falcon Fundation, Boise
- Pagel JE (1989) Use of explosives to enhance a Peregrine falco eyrie. *Journal Raptor Research* **23**:176–178
- Palmer MA, Ambrose RF, Poff NL (1997) Ecological theory and community ecology. *Restoration Ecology* **5**:291–300
- Penteriani V, Sergio F, Delgado MM, Gallardo M, Ferrer M (2005) Biases in population diet studies due to sampling in heterogeneous environments: a case study with the Eagle Owl. *Journal of Field Ornithology* **76**:237–244
- Penteriani V, Delgado MM (2016) Búho real – *Bubo bubo*. In: Salvador A & Morales MB (eds) *Enciclopedia Virtual de los Vertebrados Españoles*. Museo Nacional de Ciencias Naturales, Madrid, Spain
- Rohrer Z, Rebollo S, Gegúndez P (2018) *Guía de buenas prácticas para el avión zapador en explotaciones de áridos*. LafargeHolcim, FIRE & UAH. Madrid, Spain. https://www.researchgate.net/publication/328430344_Guia_de_buenas_practicas_para_el_avion_zapador_en_explotaciones_de_aridos (accessed 10 May 2019)
- Salvador A, Morales MB, eds. (2002) *Enciclopedia Virtual de los Vertebrados Españoles*. Museo Nacional de Ciencias Naturales – CSIC, Madrid, Spain. <http://www.vertebradosibericos.org/> (accessed 18 May 2019)
- Sergio F, Rizzolli F, Marchesi L, Pedrin P (2004) The importance of interspecific interactions for breeding-site selection: Peregrine falcons seek proximity to raven nests. *Ecography* **27**:818–826
- Sunderman A, Stoll S, Haase P (2011) River restoration success depends on the species pool of the immediate surroundings. *Ecological Applications* **21**:1962–1971
- Szép T, Für J, Molnár E (2016) A high level of nest predation observed in a large Sand Martin (*Riparia riparia*) colony. *Ornis Hungarica* **24**:46–53
- Ye S, Guo S, Dou Z, Wang Z, Lu J (2016) Nest-site selection of Sand Martin (*Riparia riparia*) in the Suburbs of Zhengzhou, Henan. *Acta Ecologica Sinica* **36**(21):1–8
- Zuberogoitia I (2016) Halcón peregrino – *Falco peregrinus*. In: Salvador A & Morales MB (eds). *Enciclopedia Virtual de los Vertebrados Españoles*. Museo Nacional de Ciencias Naturales, Madrid, Spain

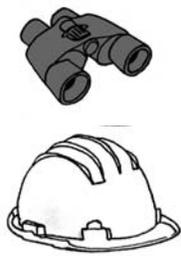



CHAPTER VII

Conclusions

CHAPTER VII

Conclusions

1. There are very few studies that address the colonization of mining sites by cliff-nesting birds, or the relevance as breeding places that these human-created habitats may have for these species. There are also very few examples in the literature of actions carried out to restore mining sites with the objective of promoting cliff-nesting birds. There is therefore a gap of knowledge that opens a new research line.
2. The cliff-nesting community that colonizes the cliff environments generated by mining activity showed, in general, a remarkable abundance of individuals, richness and diversity of species, some of which have conservation status. The community of cliff-nesting birds includes a wide range of species varying in size, breeding habitat preferences, gregariousness during reproduction, trophic ecology, degree of dependence on mining spaces and excavating behavior.
3. The Eagle Owl (*Bubo bubo*), a top predator, colonizes and breeds frequently in mining sites in the study area. The frequency with which this type of super-predator appears in the mining spaces and their capacity to predate on other species, should be taken into account to avoid generating negative effects on the rest of the cliff-nesting community that colonizes mining sites, both in their active and restoration phases.
4. The Eagle Owl behaves as a specialist predator in the mining sites, with rabbits (*Oryctolagus cuniculus*) as its main prey. Birds represent a low proportion of its diet, especially cliff-nesting species. This limits the direct effects of predation by the Eagle Owl on these species. In addition, as the community of cliff-nesting birds was more diverse in mining sites where this predator was present, the indirect effects of its presence also seem to be low, in general. Therefore, in the conditions in which our study has been carried out, the Eagle Owl is a species of conservation interest that can be promoted in the mining sites.
5. The Sand Martin (*Riparia riparia*) is a migratory, colonial, burrowing species of conservation interest, with important breeding colonies currently located in mining sites in the study area and in Europe. Its strong link with mining sites requires establishing special management and conservation measures for this species to make mining activity compatible with its conservation. For this, management guidelines based on scientific knowledge and current best practices adapted to the behavior of the species at the regional scales are essential.
6. The Sand Martin was a good model to study habitat selection of cliff-nesting species in mining sites, the relevance of mining sites as breeding habitats for cliff-nesting species, and to develop management recommendations for burrowing cliff-nesting species at aggregate sites. More studies on other species such as the studies presented in this work are needed to further understand habitat requirements of the birds that colonize mining sites and to promote and manage them in the best possible way.

7. The management of the Sand Martin both in active and restored mining sites, is a challenge. This is due to interannual dynamics of the colonies, low phenological synchronization per colony, the variety of colonized environments in mining areas (vertical faces and stockpiles), high numbers of burrows per colony, low burrow occupation rates, and the fact that it is a protected species. Management and conservation measures during the active phase of the mining sites should be based on a calendar of mining activities and the phenology of the reproduction of this species, and will require long, medium and short-term decisions, incorporating annual and local information phenology of the species.
8. The burrows generated by the Sand Martins are colonized by several species of secondary user birds that use holes to nest but do not have the capacity to excavate them. The most abundant secondary user in the mining sites was the Rock Sparrow (*Petronia petronia*), and its frequency of colonization increased with the number of holes, the presence and the abundance of nesting Sand Martins. This suggests that in addition to benefiting from the presence of holes, the secondary users may benefit from the Sand Martins' group defense.
9. There are few examples of services provided by the engineering activity of birds in the literature, and the case of the Sand Martin is a good example of this type of service. The burrowing capacity of the Sand Martin, which generates holes that facilitate the colonization of the mining sites by other cliff-nesting birds, can be applied as a service for restoration because it can increase the local abundance and diversity of cliff-nesting birds. Promoting Sand Martins and their services can be useful in restoration projects, as they generate a more self-sustaining system by increasing the number of burrows available for the reproduction of other bird species.
10. The present study supports our perspective regarding that the cliff-nesting bird community that colonizes mining sites is complex and of conservation interest. This community especially requires management and conservation measures during the active phase of the mining sites. Their conservation can be extended to the restoration phase, especially in those cliff environments already colonized by these species. The management and conservation measures of these species should not be based exclusively on the cliff habitats where they nest, but also on their feeding, resting, roosting, etc. habitats. Favoring these habitats in the mining areas would also favor spatial heterogeneity and other species. Due to the large home range of some of these species, the management of these complementary habitats should take into account the environments also located outside the mining sites.



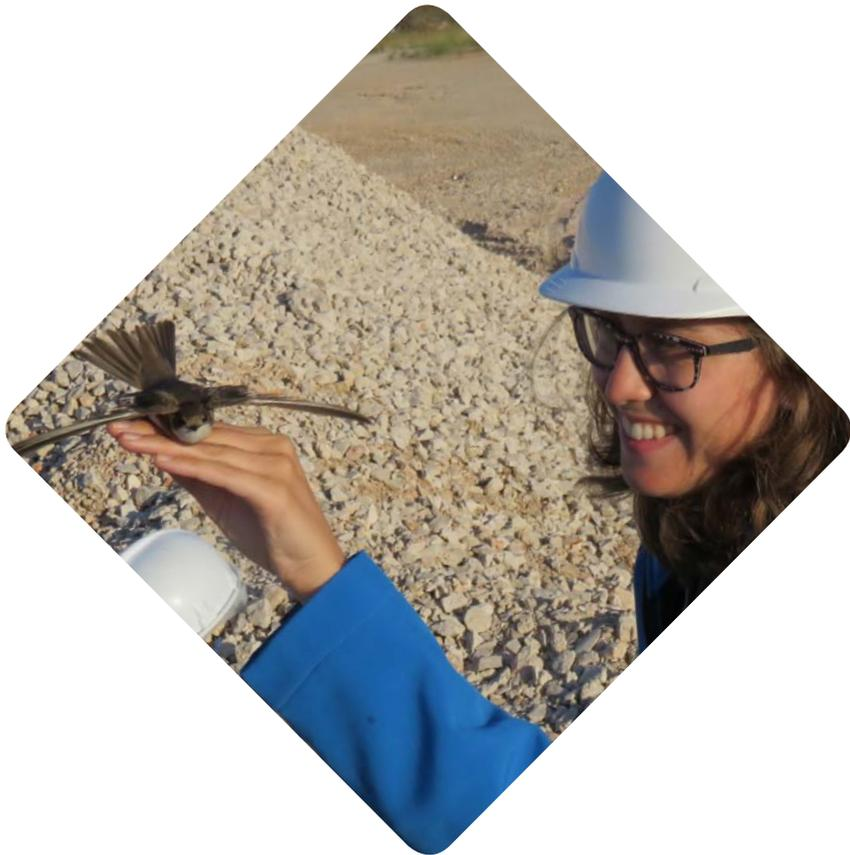

ACKNOWLEDGMENTS

Tenía muchas ganas de que llegara el día en el que tuviera la oportunidad de agradecer a todas las personas que de alguna manera u otra han estado involucradas en este proyecto. Habéis sido incontables, así que, si me falta algún nombre, espero que os alegréis de haber sido tantos los que me habéis hecho feliz, que no sea capaz de contarlos a todos.

A las instituciones que han apoyado este proyecto, y las personas que las encarnan: a LafargeHolcim España; a Raúl Pérez y muy especialmente a Pilar Gegúndez, sin cuya energía y pasión nada de esto habría sido posible. Muchas gracias por la confianza que depositaste en mí. También me gustaría agradecer a los jefes y operarios que me han acompañado en las canteras. A la Fundación FIRE: en primer lugar; a José María Rey Benayas por el inmenso respaldo de la fundación, sin quien tampoco habría podido prosperar este proyecto, y a Aurora, Fer y Miriam por haberme acompañado desde las oficinas de la FIRE. A la Universidad de Alcalá: especialmente, a Salvador Rebollo, por la ilusión con la que ha dirigido la tesis desde el primer día. A la Unidad Docente de Ecología, el grupo de investigación FORECO y a REMEDINAL (S-2013/MAE/2719). A los profesores de la Unidad Docente, sin olvidar a Lorenzo, y a Ana y a Rosi, sin quienes me habría ahogado entre todo el papeleo. A Mika, por el cariño con el que hacía mi café con leche todos los días, corto de café.

A toda la cohorte de predocs, postdocs y técnicos eco-físicos con los que he tenido la enorme suerte de coincidir. Quiero agradecerlos todos los consejos... toda la experiencia compartida... En especial, a los que me habéis ayudado con análisis o los que os habéis tomado el tiempo de aconsejarme, y sobre todo a los que me habéis tomado bajo vuestra ala (Enrique, Rafa, Marga, Judith...). Y también quiero agradecerlos a todos que hayáis compartido vuestro tiempo libre conmigo y os hayáis preocupado por mí. Ha sido maravilloso conocerlos y espero haberlos aportado una mínima parte de la que me habéis aportado a mí. Vuestra red de apoyo ha sido indispensable.

A mi despacho, "el despacho guay", os reservo un agradecimiento especial, tanto a los fijos como los esporádicos (habéis sido tantos en realidad...). No habría sido lo mismo sin vosotros. Al equipo "Gestiones", que me ha dado mucho más que simplemente la tesis. Vero y Elena, por supuesto, no puedo dejar de dedicaros una línea extra por todo el arrojo que tenéis y por todos los proyectos que habéis compartido conmigo con tanto entusiasmo, dentro y fuera del departamento. Me hace también especial ilusión darle un abrazo al grupo "Vacaciones en R" y al resto de doctorandos con los que he coincidido: Laura M. por haber sido una fuente de motivación en tantos aspectos, Navi por acogerme y ser la roomie ideal, Loreto por ser mi ancla de calma, Denis por haber organizado un viaje inolvidable para mi, Andrei, Dani, Pablo, Marta, Sonia, Julen, Luciano, Silvia, Andrea, Laura F., Joaquín... Nadie mejor que vosotros para compartir esta experiencia.

A los alumnos de máster, que han compartido el trabajo de campo conmigo y me han ayudado enormemente a avanzar en la tesis (Carlos R., Juan, Juliana).

A los técnicos, cuyo apoyo ha sido indispensable para llevar a cabo la labor de campo. Carlos T., Manolo y Javier, de los cuales he aprendido muchísimo de ornitología. También a Eloy por prestarnos los aros autoportantes.

A Brinzal, Plegadis y toda la gente de BIRS-Azufaifo, con quien también he compartido mucho estos años y me han introducido más en el mundillo de la ornitología. He aprendido mucho en el campo con todos vosotros y me he reído muchísimo también. Muchas gracias por las fotografías que me habéis prestado, Beltrán Ceballos y Francisco Rosa García.

A los complutenses (Fer, Alba, Sara, Irene... la gente de Agua de Mayo... también sois muchísimos), que una vez que conseguí encontraros, hicisteis de la experiencia de vivir en Alcalá algo inolvidable. Muchas gracias por todos esos bailes y por haberme incluido en el grupo de swingueros.

A mis biólogos (Marta, Olga, Ainhoa, Bárbara), que también han compartido muy de cerca todos mis trasiegos y me han ofrecido su amistad tan generosamente.

A Luis Balaguer, porque sin su inspiración no habría dedicado tantos años a la Restauración Ecológica.

A mi familia. Desde mi abuelo de 93 años a mi primo menor, todos han contribuido de alguna manera, aún sin saberlo. Quiero aprovechar para darle un abrazo especial a mi madre, que me enseña cada día lo que es la constancia, la superación y la ilusión. Su fuerza realmente me inspira. A mi hermano, porque sin los gadgets que me ha ido prestando no habría conseguido avanzar tanto y tan bien. A mi padre, por enseñarme la pasión inconmensurable por aprender.

A José. Muchas gracias José, por todo. Eres una persona increíble y te agradezco que me hayas regalado tantos momentos y me hayas prestado un espacio fuera de la tesis para respirar. También me siento inmensamente agradecida por haberme cuestionado, impulsado y acompañado a descubrir tantas cosas. Y especialmente, me siento agradecida por poder compartir contigo tantas de mis pasiones. Por ello me gustaría dedicarte esto:



Muchas gracias.

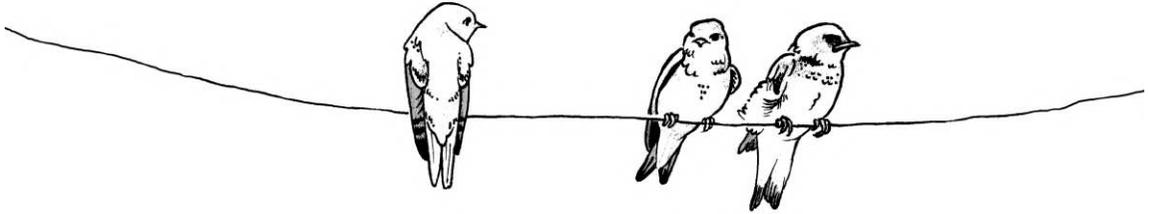

SUPPORTING INFORMATION CHAPTER III

Table S3.1 Total minimum prey, number of pellets and percentage of prey for each taxonomic group per mining site. Mining sites are ordered in descending total minimum prey values.

Mining site	Number of pellets	% Mammal	% Bird	% Reptile	% Invertebrate	% Amphibian
EMA	24	81	15	1	0	2
LPO	58	88	7	1	2	1
MOS	45	89	9	0	1	1
VIL	52	63	36	1	0	0
LCH	35	63	19	18	0	0
EMO	59	100	0	0	0	0
LSO	34	73	27	0	0	0
OLI	22	93	5	0	2	0
ESP	40	95	5	0	0	0
CTO	36	88	4	4	4	0
YEP	27	84	16	0	0	0
Total	432	83	13	2	0.8	0.5

Table S3.2. Abundance of species in the Eagle Owl's diet per site. Mining sites are ordered in descending order of total minimum number of prey. Species are ordered by taxonomic group and abundance in the diet.

Mining site	Mammals														Birds										Reptiles			Amphibians		Inv.	Prey per site						
	<i>Oryctolagus cuniculus</i>	<i>Apodemus sylvaticus</i>	<i>Rattus</i> sp	<i>Microtus duodecimcostatus</i>	<i>Mus</i> sp	<i>Mus spretus</i>	<i>Arvicola sapidus</i>	<i>Micromamifero indet</i>	<i>Marmifero indet</i>	<i>Erinaceus europaeus</i>	<i>Lepus granatensis</i>	<i>Lagomorfo indet</i>	<i>Ave indet</i>	<i>Sturnus</i> sp	<i>Colomba palumbus</i>	<i>Colomba</i> sp	<i>Columba palumbus</i>	<i>Pica pica</i>	<i>Corvido indet</i>	<i>Corvus monedula</i>	<i>Fringillido indet</i>	<i>Paserforme indet</i>	<i>Alectoris rufa</i>	<i>Falco tinnunculus</i>	<i>Fulica atra</i>	<i>Rapaz indet</i>	<i>Turdus philomelos</i>	<i>Tyto alba</i>	<i>Reptil indet</i>			<i>Timon lepidus</i>	<i>Ofidio indet</i>	<i>Anuro indet</i>	<i>Bufo</i> sp	<i>Pelobates cultripes</i>	
EMA	12	47		6	2				1			3	3	1	1	1						3										1	1	1			86
LPO	60	4	1	3	3							1	1	1				2	1					1								1	1	1	2	2	81
MOS	56		12									5						1					1							1					1	1	80
VIL	43	1	1		1	1					1	4	18	2	2								1	1												75	
LCH	34	2	2	3	1		1	1				7		2	2	1			2	1							1	1	10	2	1				72		
EMO	57	2	11	1								3	2													1									71		
LSO	43		2									3	2	6	1												1									61	
OLI	34	10	2	10				1				1		1		1									2								1	1	61		
ESP	40	3	7	1								2	1																							60	
CTO	38	1						1	1	1		1	1	1															2						2	48	
YEP	31											1	2	3																						37	
Total	448	70	38	24	7	7	4	3	2	1	1	28	22	16	6	5	4	4	4	3	3	2	1	1	1	1	1	1	13	3	1	2	2	1	6	732	

Table S3.3 Rabbit activity estimated from pellets, latrines, burrows y scratches. Parameters are percentage of survey points with rabbit pellets, average density of rabbit pellets, percentage of survey points with latrines, burrows, and scratches, average minimum distances (m) to the closest latrine, burrow and scratching. Mining sites are ordered alphabetically.

Mining site	% Points with pellets	Average density of pellets	% Points with latrines	Latrine average minimum distance	% Points with burrows	Burrow average minimum distance	% Points with scratches	Scratch average minimum distance
ALM	44	60	56	14	7	19	70	13
CER	5	0	10	19	5	19	10	19
COR	0	0	0	20	0	20	0	20
CTO	58	23	48	14	16	18	58	11
DOL	44	17	47	15	38	16	69	11
EBU	10	2	20	18	0	20	13	19
EMA	30	5	18	18	6	19	45	16
EMO	0	0	0	20	0	20	0	20
EPU	97	110	100	7	60	15	100	6
ESP	3	0	3	19	7	19	10	19
FON	19	2	23	18	0	20	27	18
GAR	3	8	3	20	0	20	0	20
LCH	0	0	0	20	0	20	0	20
LPO	47	17	40	13	33	15	50	11
LSO	43	20	43	14	20	18	53	12
MON	27	7	23	18	3	20	17	18
MOS	37	9	53	14	40	16	73	11
OFR	12	6	23	17	12	19	23	16
OLI	7	1	7	19	0	20	7	19
PRE	90	26	70	10	30	17	100	5
REM	96	93	96	5	22	18	100	3
RET	0	0	0	20	0	20	0	20
ROM	77	36	73	10	40	15	80	8
SCA	38	24	42	16	42	15	46	13
SLL	13	7	13	19	3	20	19	18
TER	42	10	25	16	0	20	42	14
VIL	86	119	82	8	50	15	86	7
YEP	68	71	68	9	64	12	84	8

Table S3.4 Correlations between the rabbit activity parameters and the axis I of the PCA calculated with these activity parameters.

	% Points with pellets	Average density of pellets	% Points with latrines	Latrine average minimum distance	% Points with burrows	Burrow average minimum distance	% Points with scratches	Scratch average minimum distance	PC1
% Points with pellets	1.000	0.825	0.968	-0.969	0.770	-0.712	0.961	-0.976	-0.97
Average density of pellets	0.825	1.000	0.864	-0.873	0.704	-0.618	0.775	-0.782	-0.86
% Points with latrines	0.968	0.864	1.000	-0.978	0.814	-0.744	0.966	-0.966	-0.98
Latrine average min. distance	-0.969	-0.873	-0.978	1.000	-0.800	0.747	-0.945	0.973	0.98
% Points with burrows	0.770	0.704	0.814	-0.800	1.000	-0.973	0.805	-0.810	-0.89
Burrow average min. distance	-0.712	-0.618	-0.744	0.747	-0.973	1.000	-0.753	0.764	0.84
% Points with scratches	0.961	0.775	0.966	-0.945	0.805	-0.753	1.000	-0.977	-0.97
Scratch average min. distance	-0.976	-0.782	-0.966	0.973	-0.810	0.764	-0.977	1.000	0.97
PC1	-0.97	-0.86	-0.98	0.98	-0.89	0.84	-0.97	0.97	1.00

Table S3.5 Percentages of mammals, rabbits, birds, invertebrates, amphibians, reptiles and fish in the diet of the Eagle Owls in different studies conducted in central and East Spain. The studies are ordered alphabetically. The groups are ordered in descending percentages.

Author	% mammal	% rabbit	% bird	% inverteb	% amphib.	% reptile	% fish	Location
Present study	83.1	61.26	13.2	0.8	0.7	2.2	0	Central Spain
Antón et al. 2008	90.08	71.95	9.92	0	0	0	0	Alicante
Jaksic et al. 1984	65.3	0.81	25.1	5.9	0.3	0.8	2.6	Mediterranean ecosystems
Martínez and Zuberogoitia 2001	65.2	33.8	30.7	3.6	0	0.5	0	Alicante
Pérez 1980	79.38	61.5	16.7	0.7	1.8	0.3	0	Central Spain
Serrano et al. 1998	78.99	12.48	10.87	7.2	0	2.43	0.52	Valle medio of the Ebro River, Zaragoza
Tobajas et al. 2016	78.52	67.76	17.605	3.29	0	0.555	0	Central Spain
Zarco et al. 2016	83.76	60.08	14.96	0.72	0.32	0.16	0.08	Madrid

SUPPORTING INFORMATION CHAPTER IV

Table S4.1 Variable selection for the habitat preferences of the Sand Martins at the three studied spatial scales (mining site, colony and burrow scales). Significant predictor variables for each studied response variable are presented with an Asterix (*)

Scale	Response variable	Significant predictor variables	Statistic	<i>p</i>
Mining site scale	Presence of Sand Martins	Distance of the mining site to running water	H = 121.5	0.055*
		Age of the mining site	H = 128.5	0.031
		Distance of the site to water bodies	H = 112.5	0.067*
	Abundance of Sand Martins	Distance of the mining site to running water	<i>r</i> = - 0.36	0.056 *
		Age of the mining site	<i>r</i> = - 0.36	0.059 *
	no. of burrows	Age of the mining site	<i>r</i> = - 0.40	0.031
		Distance of the site to water bodies	<i>r</i> = - 0.65	<0.001
		Distance of the site to running water	<i>r</i> = - 0.61	<0.001
		Surface of water bodies in a 1 km buffer	<i>r</i> = 0.42	0.022
		Surface of extractive industry in a 1 km buffer	<i>r</i> = 0.40	0.03
		Regional Sand Martin abundance	<i>r</i> = 0.44	0.016
		Type of extraction	H = 12.60	0.002
Colony scale	Abundance of Sand Martins	Orientation of the structure	<i>r</i> = 0.48	0.01
		Height of talus	<i>r</i> = 0.40	0.037
		Age of the structure	<i>r</i> = - 0.44	0.019
		Vegetation cover on talus	<i>r</i> = - 0.44	0.018
		Vegetation cover on the upper area of the structure	<i>r</i> = - 0.52	0.005
		Type of structure	T = 164.5	0.001
	no. of burrows	Length of the structure	<i>r</i> = 0.46	0.014
		Vegetation cover on the vertical surface of the structure	<i>r</i> = 0.48	0.01
Burrow scale	Stockpiles	Slope	T = 745	< 0.001
		Total height of the structure	T = 981	0.023
		Total vertical height of the structure	T = 930	0.009

Variable selection at mining site scale

The abundance of Sand Martins for the 29 mining sites showed an almost significant negative relationship with the distance of the mining site to running water and the age of the mining site. The best supported Zero-inflated model based on AICc included the effect of the distance to running water, and the age of the mining site on the abundance of Sand Martins.

The number of burrows per mining site showed a significant negative relationship with the age of the mining site, the distance of the site to water bodies, and the distance of the site to running water. The relationship was positive for the surface of water bodies, surface of extractive industry, and regional Sand Martin abundance. The regional Sand Martin abundance was correlated to the distance of the site to water bodies ($r = -0.67$, $p < 0.01$), thus we excluded the regional Sand Martin abundance from the model. Regarding categorical predictors, the type of extraction had a significant relationship with the number of burrows, whereas the type of extracted material did not ($T = 128$, $p = 0.079$). The type of extraction was related to four variables: the distance of the site to water bodies ($H = 13.96$, $p < 0.01$), distance to running water ($H = 8.744$, $p = 0.013$), surface of water bodies ($H = 12.96$, $p = 0.002$) and surface of extractive industry ($H = 6.5325$, $p = 0.038$). Two Zero-inflated models were adjusted to analyze all the variables: 1) Including the 4 continuous variable: the distance to water bodies, the

distance to running water; the surface of extractive surface and the surface of water bodies on the number of burrows; 2) Including the age of the site and the type of extraction, because the type of extraction is important in providing the structures where Sand Martins construct their colonies and to avoid multicollinearity with the other four continuous variables.

Variable selection at colony scale

The abundance of Sand Martins in the colonies showed a significant positive correlation with the orientation of the structure, and height of talus, while a negative one for the age of the structure, vegetation cover on talus, and vegetation cover on the upper area of the structure. The vegetation cover on the upper area of the structure was correlated with the vegetation cover on the talus ($r=0.61$, $p<0.01$). We selected vegetation cover on the upper area of the structure, to avoid collinearity. Regarding the categorical predictors, the type of structure (vertical extraction face or stockpile) was significantly related to the abundance of Sand Martins, to the age of the structure ($T = 46.5$, $p = 0.022$), and to the height of the talus ($T = 145.5$, $p = 0.019$). We rejected the height of the talus and the age of the structure, since they were less significant for the abundance of SMs. The best supported model based on AICc included the type of structure, the orientation, and the vegetation cover on the upper area of the structure.

Two predictor variables correlated positively with the number of burrows in the colony: length of the structure and vegetation cover on the vertical surface. The best supported model based on AICc included the effect of the vegetation cover on the vertical surface of the structure and the length of the structure on the number of burrows.

Variable selection at burrow scale

Regarding vertical extraction faces ($n=129$), none of the predictor variables had a significant relationship with the binomial response variable (availability versus use), and therefore no further analyses were performed.

For the stockpiles ($n=103$), the slope, the total height of the structure and the total vertical height of the structure had a significant positive relationship with the response variable. The total height and the total vertical height correlated ($r=0.68$, $p<0.001$). The best supported model based on AICc included the height of the vertical surface of the structure and the slope.

Table S4.2 Number of colonies, burrows and Sand Martin pairs per mining site. Mining sites are ordered in increasing number of burrows.

Mining site	no. of colonies	no. of burrows	Sand Martin abundance
CTO	1	38	4
EMO	1	1070	40
PRE	1	1155	0
EPU	2	520	0
LPO	2	916	125
ESP	3	365	124
LCH	3	161	6
MAT	3	522	249
COR	5	972	70
ROM	7	2752	25
Total	28	8471	643

Table S4.3 Number of burrows, Sand Martin pairs, age and type of structure in the 30 colonies (stockpiles or vertical extraction faces). Colonies are ordered in increasing number of burrows per mining site.

Colony	Mining site	no. of burrows	Sand Martin abundance	Age of colony (years)	Type of structure
COR2	COR	40	5	8	stockpile
COR5		40	0	10	vertical face
COR6		240	0	6.5	vertical face
COR4		243	2	9	vertical face
COR1		409	63	3.5	stockpile
CTO1	CTO	38	4	9	vertical face
EMO1	EMO	1070	40	3	stockpile
EPU3	EPU	227	0	5	vertical face
EPU1		293	0	3.5	vertical face
ESP3	ESP	6	0	1	stockpile
ESP2		43	0	4	vertical face
ESP1		316	124	0.5	stockpile
LCH3	LCH	10	1	6.5	stockpile
LCH2		67	1	6.5	stockpile
LCH1		84	4	9	stockpile
LPO2	LPO	105	34	4	stockpile
LPO1		811	91	4	vertical face
MAT3	MAT	117	50	0.5	stockpile
MAT2		168	70	3	stockpile
MAT1		237	129	3	stockpile
PRE1	PRE	1155	0	6.5	vertical face
ROM6	ROM	30	0	8	vertical face
ROM3		83	0	2	vertical face
ROM2		84	1	2	vertical face
ROM8		143	0	8	vertical face
ROM5		510	0	4	vertical face
ROM1		578	24	1.5	vertical face
ROM7		1324	0	8	vertical face

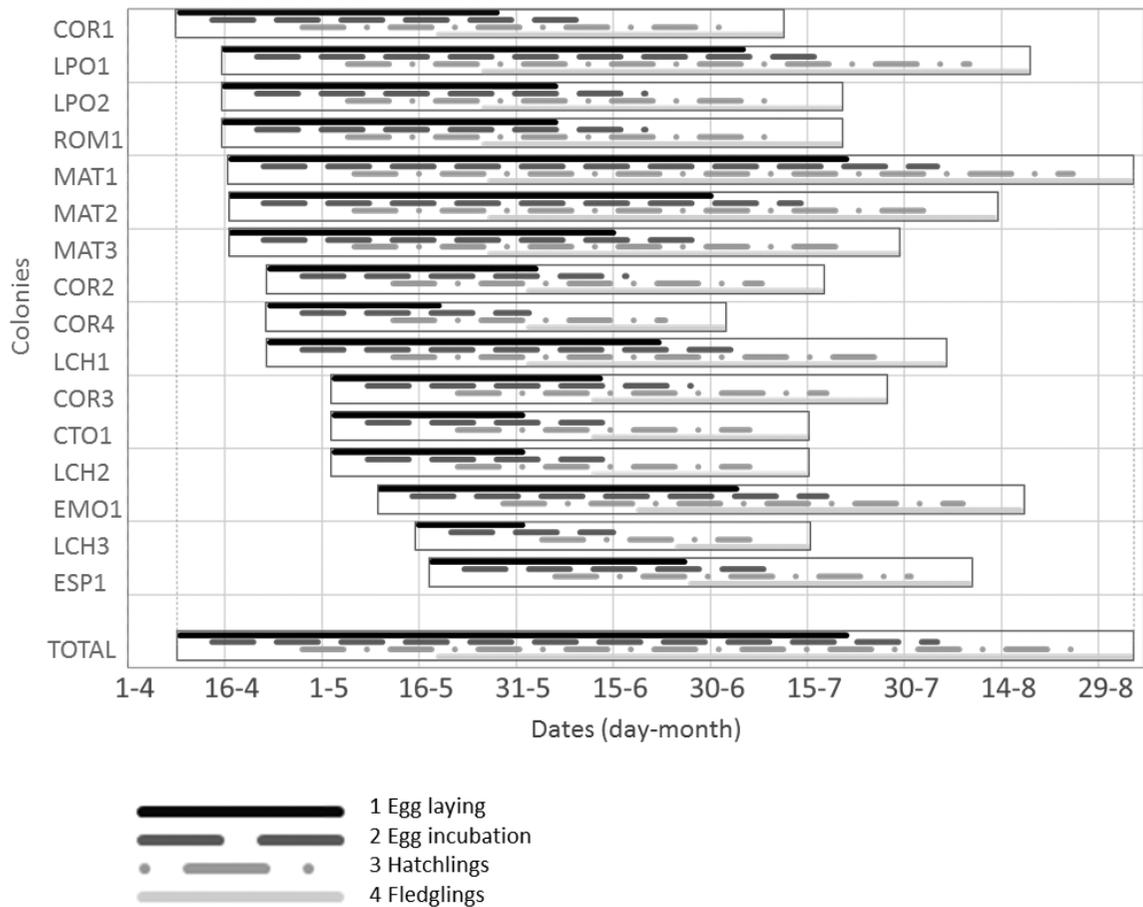

Figure S4.1 Phenology of the Sand Martin colonies with breeding activity in our study area.

Periods were estimated based on Petersen (1955). Colonies are ordered from the most advanced to the latest, regarding the egg-laying phase. Within the colonies, a mismatch was observed between breeding Sand Martins. The largest difference was observed in the colony MAT1, where the egg-laying phase lasted for 13 weeks. There was also a wide time difference between colonies located at different mining sites, reaching more than one month between the most advanced and delayed colonies. These differences within the colonies and between mining sites extend the breeding period from the beginning of April (beginning of egg laying at the most advanced colonies) until the end of August (last fledglings of the most delayed pairs).

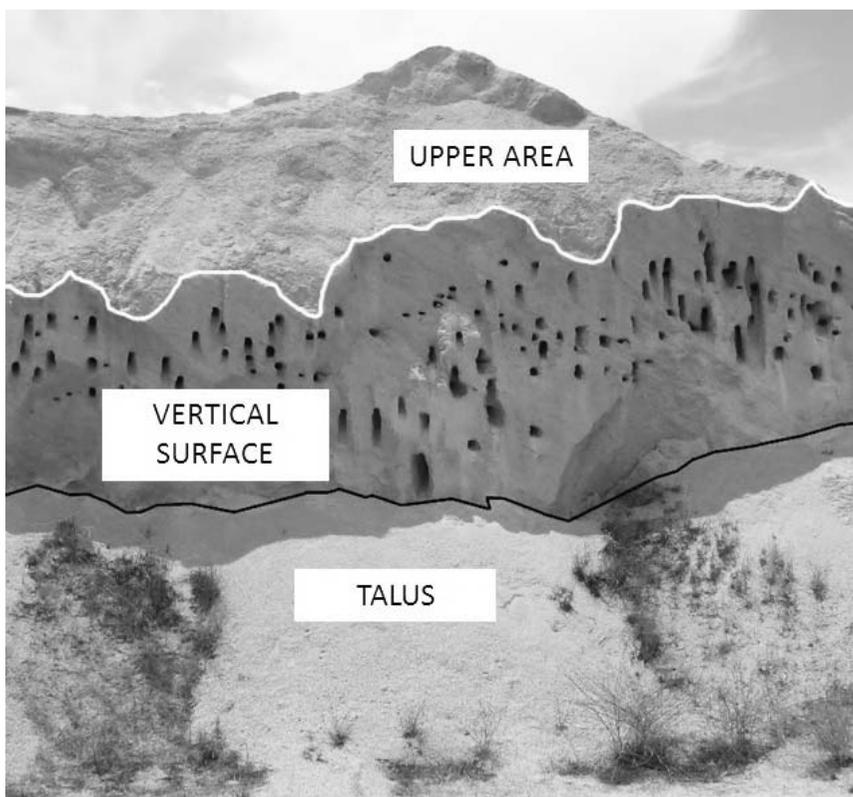

Figure S4.2 Diagram of a stockpile with upper, vertical and talus areas.

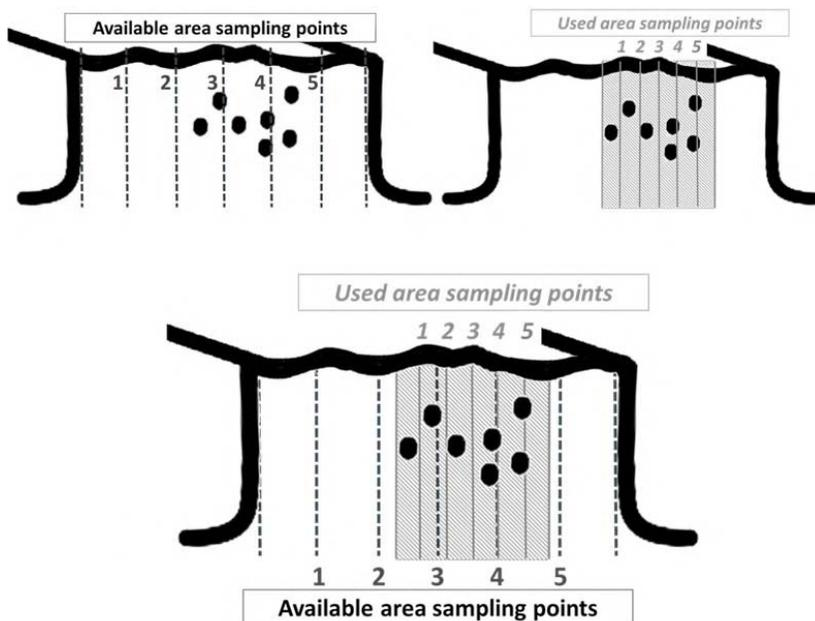

Figure S4.3 Diagram of available area and used area sampling points in each colony at burrow scale.

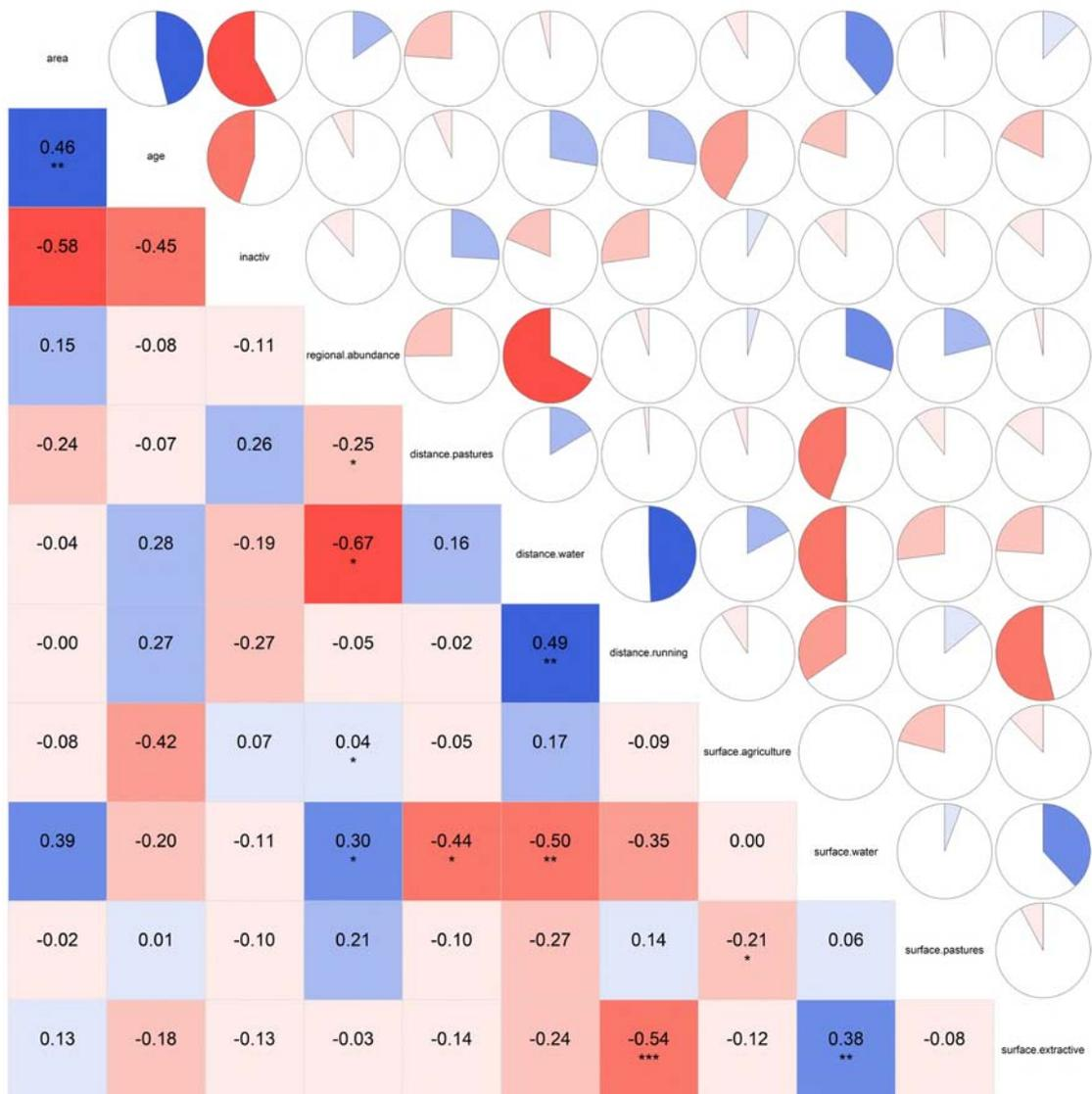

Figure S4.4 Correlation matrix of the predictor variables at the mining site scale.

Mining sites ($n = 29$) in black. Predictor variables in red: “age”: Age of the mining site; “area”: Surface of the mining site; “distance.pastures”: Distance to pastures; “distance.running”: Distance to running water; “distance.water”: Distance to water bodies; “Inactiv”: Years of mining inactivity; “regional.abundance”: Regional Sand Martin abundance; “surface.agriculture”: Surface of agricultural fields; “surface.extractive”: Surface of extractive industry; “surface.pastures”: Surface of pastures; “surface.water”: Surface of water bodies.

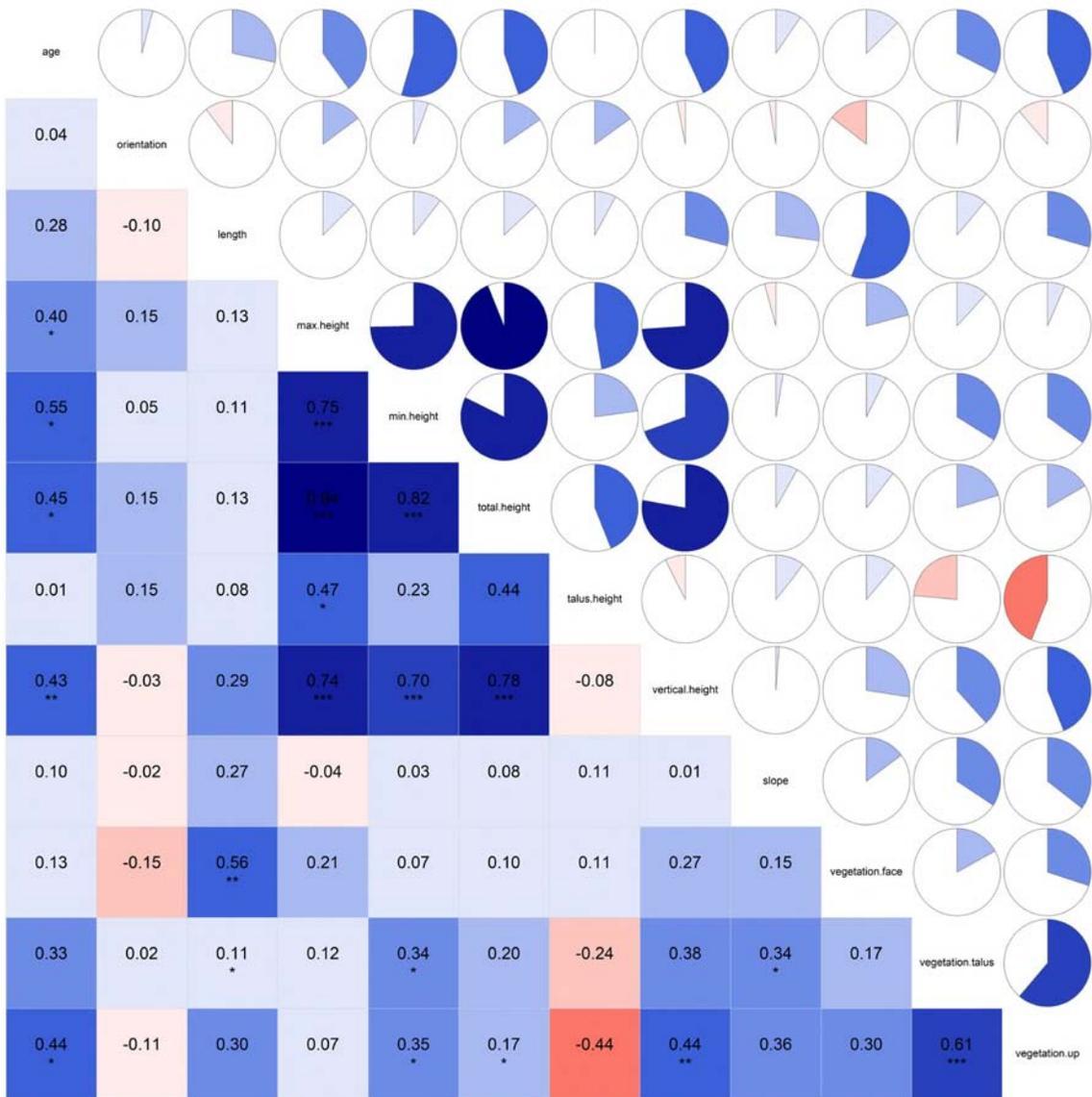
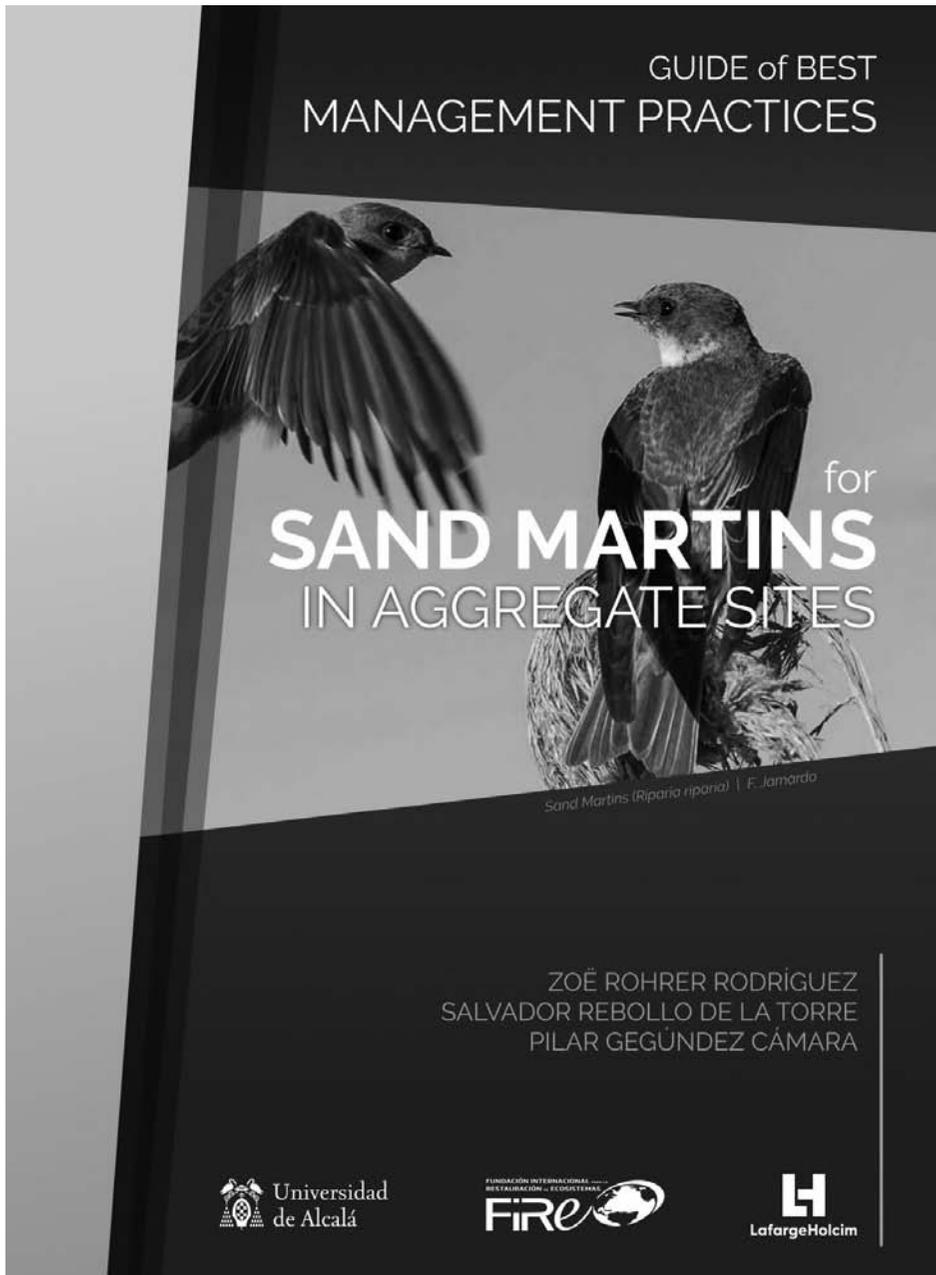

Figure S4.5 Correlation matrix of the predictor variables at the colony scale.

Colonies ($n = 28$) in black. Predictor variables in red: “**age**”: Years since the face was created; “**length**”: Total length (m) of the face; “**min.height**”: Minimum height (m) of the face; “**max.height**”: Maximum height (m) of the face; “**orientation**”: orientation of the face; “**slope**”: Slope (degrees) of vertical area of the face; “**total.height**”: Mean height (m) of the face; “**talus.height**”: Mean height (m) of the fallen material at the base of the face (talus); “**vegetation.face**”: Percentage of vegetation cover on the vertical area of the face; “**vegetation.talus**”: Percentage of vegetation cover on the talus (fallen material at the base of the face); “**vegetation.up**”: Percentage of vegetation cover on the upper area of the face; “**vertical.height**”: Mean height (m) of the vertical surface.

APPENDIX S4.1

Guide of best management practices for Sand Martin in aggregate sites:



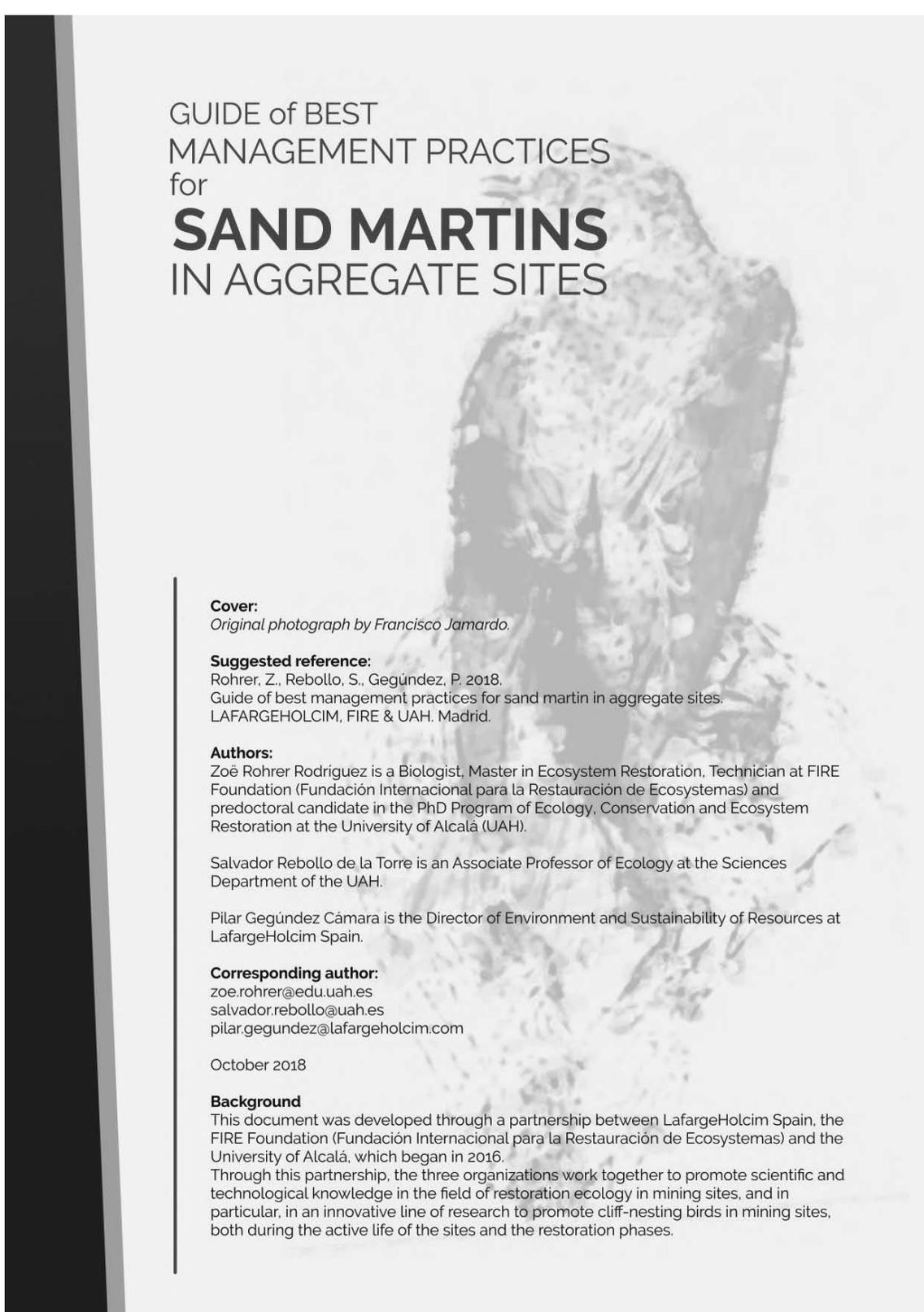

GUIDE of BEST MANAGEMENT PRACTICES for **SAND MARTINS** IN AGGREGATE SITES

Cover:

Original photograph by Francisco Jamardo.

Suggested reference:

Rohrer, Z., Rebollo, S., Gegúndez, P. 2018.
Guide of best management practices for sand martin in aggregate sites.
LAFARGEHOLCIM, FIRE & UAH. Madrid.

Authors:

Zoë Rohrer Rodríguez is a Biologist, Master in Ecosystem Restoration, Technician at FIRE Foundation (Fundación Internacional para la Restauración de Ecosistemas) and predoctoral candidate in the PhD Program of Ecology, Conservation and Ecosystem Restoration at the University of Alcalá (UAH).

Salvador Rebollo de la Torre is an Associate Professor of Ecology at the Sciences Department of the UAH.

Pilar Gegúndez Cámara is the Director of Environment and Sustainability of Resources at LafargeHolcim Spain.

Corresponding author:

zoe.rohrer@edu.uah.es
salvador.rebollo@uah.es
pilar.gegundez@lafargeholcim.com

October 2018

Background

This document was developed through a partnership between LafargeHolcim Spain, the FIRE Foundation (Fundación Internacional para la Restauración de Ecosistemas) and the University of Alcalá, which began in 2016.

Through this partnership, the three organizations work together to promote scientific and technological knowledge in the field of restoration ecology in mining sites, and in particular, in an innovative line of research to promote cliff-nesting birds in mining sites, both during the active life of the sites and the restoration phases.

THE SAND MARTIN

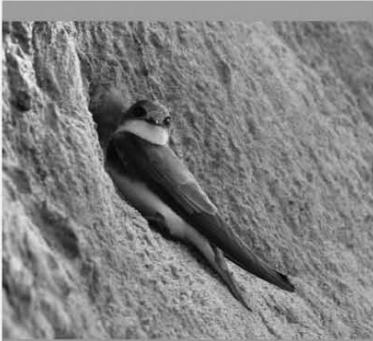

Figure 1
Adult sand martin
Source: Aiwar - Own work, CC BY-SA 3.0

The sand martin (*Riparia riparia*) is a migratory species, with conservation interest in Europe. It is recognizable by its brown upper side, white lower side, and a characteristic dark chest bar (Figure 1). It is gregarious, and its natural breeding habitats are the banks of rivers and other water bodies, though very often it can be found in man-made aggregate pits. It excavates burrows in sandy vertical cliffs, at the end of which their nests are located. In the last decades, and in large areas of its global distribution, the sand martin has increased the use of mining areas as breeding sites, where it concentrates its main breeding colonies. This is an opportunity for the aggregate sector to

positively contribute to the conservation of this threatened species and to promote local biodiversity.

The objective of this guide is to help reconcile mining activity and the conservation of the sand martin both during the active and restoration phases of a mining site. These recommendations can be easily carried out by the staff at the mining sites, without previous extensive knowledge of the biology and ecology of the species.

Management recommendations

These guidelines are organized around an annual calendar which takes into account the mining activities of each site and the migration periods of the sand martin. The document is divided in dissemination, preparatory and preventive, and protective measures (Table 1).

Table 1. General action calendar.

Period	Oct.	Nov.	Dec.	Jan.	Feb.	Mar.	Apr.	May.	Jun.	Jul.	Aug.	Sep.
Measures	Normal extraction			Dissemination and preparatory measures			Normal extraction and preventive and protective measures				Normal extraction	

The objective of these guidelines is to help the Environmental Department of the mining companies to decide where the sand martin colonies may establish or not, acting on the slopes of the vertical extraction faces and stockpiles, and organizing all of the actions around the planned mining activities so that the sand martins do not interfere with them. This Guide establishes an action calendar for the inactive areas of the mining site (Table 2), where the sand martins will be protected and will be able to nest normally, and a calendar of actions for active areas of the site (Table 3), where sand martin colonies will be avoided so that mining activities will not affect their reproduction.

Organization of the measures in active and inactive areas:

Table 2. Calendar for specific actions in inactive areas.

Inactive areas	Oct.-Dec.	Jan.	Feb.	Mar.	Apr.	May.	Jun.	Jul.	Aug.	Sep.
Extraction	Normal extraction		Preparatory measures		Protective measures and regular monitoring					Normal extraction
Management	Normal extraction	Establish measures	Disseminate	Mark area	Non colonized areas: monitor and maintain				Reporting	

Table 3. Calendar for specific actions in active areas.

Active areas	Oct.-Dec.	Jan.	Feb.	Mar.	Apr.	May.	Jun.	Jul.	Aug.	Sep.
Extraction	Normal extraction		Prevention measures and periodical monitoring. Normal extraction with monitoring. Decrease slope to <60° if burrows appear.					Normal extraction		
Management	Normal extraction	Establish measures	Disseminate	Temporarily stop activity where a colony establishes					Disseminate	

A

Period: February to 15th March

a.1

Preparatory measures

Establish conservation measures for sand martins, considering the scheduled mining activities. Implement the conservation measures in February, before sand martins arrive.

a.1.1

Active vertical extraction faces and stockpiles: dissuade sand martin colonization

Normal extraction, while monitoring active vertical faces to detect sand martin presence quickly.

If burrows and sand martins are detected, decrease the slopes of the stockpiles and vertical extraction faces immediately to less than 60°, to avoid sand martins from starting to burrow again (Figures 2 and 3).

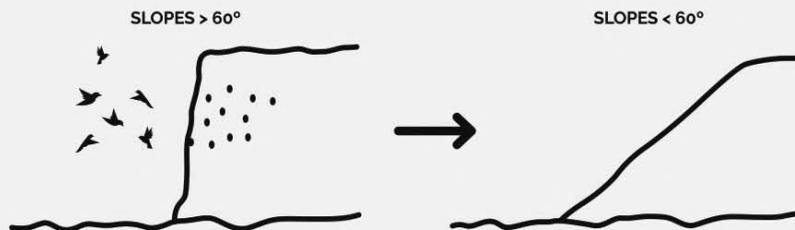

Figure 2 Right: appropriate slopes for sand martins; Left: decreased slopes to avoid sand martin colonization. Source: Adapted from Government of Canada (2017).



Figure 3
Active stockpiles without vertical faces. Both stockpiles dissuade sand martins from making burrows in them.
Source: FlickrCommons.

The extraction with slopes under 60° while monitoring non-occupied active areas will continue until mid-July, when sand martins normally cease to lay eggs.

a.1.2

Inactive vertical extraction faces: promote sand martin colonization.

Preparation of inactive extraction faces should be carried out during winter, so that they are ready when sand martins arrive in spring.

SELECT LOCATION

- ▲ Both at inactive extraction faces and stockpiles.
- ▲ Far from mining activity and paths that are frequently used by people or machinery.
- ▲ Select compact materials, but that may be easily burrowed by sand martins:
 - ▲ Stockpiles of non-washed sand of 0-6 mm grain.
 - ▲ Vertical extraction faces with sand and silt and low gravel content.
- ▲ Close to water where they can feed, such as clean water shallow ponds, with high insect production.
- ▲ Orient the vertical faces towards open spaces without obstacles (trees, buildings...) around 20-25 m of the colonies, to allow easy access to the birds.



Figure 4
Sand martin colonies in an inactive stockpile (left) and extraction face (right).
Source: Zoë Rohrer (Sodira and LafargeHolcim).

PREPARATION

- ▲ Prepare a vertical face. Dimensions:
 - ▲ Stockpiles: 4-6 m high and at least 4 m long.
 - ▲ Extraction faces: 4-6 m high and at least 20 m long.
- ▲ Slope as vertical as possible, higher than 70° (Figure 5).
- ▲ In the vertical faces, small holes to attract sand martins can be made manually: 5 cm of diameter and depth, separated at least 20 cm from each other.
- ▲ Eliminate woody vegetation from the vertical face and in the 10 m in front of it.
- ▲ Repeat these same actions every two years.



Figure 5
 Left: Backhoe preparing a vertical face for sand martins at an inactive extraction face.
 Right: Final result. Source: Zoë Rohrer (LafargeHolcim).

MAINTENANCE OF VERTICAL FACES USED IN PREVIOUS YEARS BY SAND MARTINS

- ▲ Restore verticality of the slope by cutting back the first 50 cm in those areas that are deemed necessary (Figure 5).
- ▲ Maintain some of the old burrows so that they act as attracting elements for sand martins.
- ▲ Eliminate fallen material (scree) from the base of the vertical faces.
- ▲ Increase if possible the available vertical surface.
- ▲ Remove woody vegetation from the vertical face and 10 m in front of the face.
- ▲ Prepare signs to mark the area.
- ▲ Prepare the vertical faces every two years.
- ▲ Prepare the signs and carry out marking and dissemination every year.

a.2 Dissemination measures

- ▲ Make the staff aware of the importance of protecting and conserving this species.
- ▲ At the beginning of the preparation measures, inform the staff about the actions which will be carried out for sand martins.
- ▲ Inform the staff about the location of the areas which will be prepared for sand martin reproduction, actions to avoid accidental interventions both to the preparatory measures and the established colonies.

- ▲ Mark and delimit the areas for sand martins, including colonies that may establish.
- ▲ Inform about the signs and barriers to protect sand martins so that the staff can interpret their meaning correctly.

B**Period: 15 March – August****b.1****Actions on the vertical extraction faces and stockpiles****b.1.1****Active extraction faces and stockpiles not colonized by sand martins.**

- ▲ If new sand martin burrows appear, immediately decrease the slopes to less than 60° in the active extraction faces and stockpiles.
- ▲ If a colony establishes (if there is the risk that some pairs might have begun to incubate, which usually occurs a week after the burrows have been excavated), the mining activity should temporarily cease where the colony has established, and the environmental consultant or technician at the site should be notified, to evaluate whether the extraction may continue normally.
- ▲ In the event of temporarily halting mining activities at a specific area, apply the same protection measures as described for inactive extraction faces until August. Normal extraction may resume in September.

b.1.2**Inactive extraction faces and stocks colonized by sand martins.**

- ▲ Avoid permanent mining activity at 20–50 m around the colonies.
- ▲ Mark and delimit the presence of colonies with barriers and signs (*Figure 6*).
- ▲ Inform the staff about the presence and location of the colonies. Create awareness about the importance of protecting these colonies.
- ▲ Monitor regularly:
 - ▲ The state of the barriers and signs.
 - ▲ In inactive extraction faces or stockpiles without sand martins, monitor as well and continue maintaining the faces in optimum condition until mid-July, to try to attract sand martins.

Figure 6
 Barriers to protect sand martin colonies.
 Source: Bachmann et al. (2008).
 Guide de promotion de l'hirendelle de rivage en Suisse.



P5

b.2 Dissemination measures

- ▲ Maintain the signs and barriers in optimal condition during the entire period of sand martin presence (until the end of August).
- ▲ Record and report the presence of sand martins (approximate number of burrows, orientation, signs of breeding, location, photographs...).

C Period: September to February

C.1 Measures both in active and inactive extraction faces and stockpiles

- ▲ Normal extraction.

C.2 Dissemination measures

- ▲ Inform about the presence and location of sand martin colonies and report with photographs of them to the environmental department of the company at regional and national level, and to the organization in charge of collecting and organizing information at sector level.
- ▲ Inform of the actions developed for the promotion and protection of sand martins, and the lessons learned (whether actions were successful or not; encountered difficulties and overcome challenges, etc.).
- ▲ Propose measures for the following year, based on the experiences and results from the previous year.

Management of areas other than nesting habitats

The establishment and success of sand martin colonies is influenced by the management of the surrounding areas around the nesting sites, and their provision of the rest of requirements the birds need.



Sand martins feed on small aerial insects in open areas, such as ponds, wetlands, pastures and grasslands.

- ▲ Locate the colonies near open water bodies.
- ▲ Promote open grassland areas near the colonies.
- ▲ Promote shallow ponds with high insect production.
- ▲ Maintain the ponds that appear spontaneously in the site during the breeding period.
- ▲ Avoid mining activity in the ponds located near the occupied colonies.
- ▲ Avoid the use of herbicides and pesticides in the feeding areas.



ROOSTING AREAS

Sand martin adults cease sleeping in the colonies when the chicks begin to grow. Adults sleep in communal roosting areas, which are usually located in wetlands with reed beds, mainly during May and August.

- ▲ Promote reeds in the larger water bodies (wetlands).
- ▲ Maintain the existing riparian vegetation at the site.
- ▲ Avoid the use of herbicides and pesticides in potential roosting areas.

Mining restoration

The creation of habitats for the sand martin is an option that could be taken into consideration in mining restoration plans. This option is especially indicated if the mining site was colonized by sand martins when it was active. If this option is considered, the actions which should be implemented to favour the sand martin habitats are similar to the ones described previously in this document.

The recommendations in this document can be incorporated as measures to promote biodiversity in mining restoration. The objective would be to manage the entire site comprehensively, by creating different types of habitats, including aquatic, terrestrial and vertical faces, to contribute to promote local biodiversity. This would allow sand martins, as well as many other species, to find their basic habitat requirements. Some of the most basic recommendations are:

- ▲ Maintain low extraction faces for sand martins, following the specifications in the section for preparing inactive extractive faces in this document.
- ▲ Maintain attractive stockpiles for sand martins, following the specifications for preparing inactive faces. Even if sand martins do not colonize them continuously over time, their burrows will allow other cliff-nesting species (secondary users) such as different species of sparrows to colonize the sites.
- ▲ The vertical faces that remain in the site (both extraction faces and stockpiles) should always incorporate security measures.
- ▲ Favour aquatic habitats, both shallow and deep, and open spaces with herbaceous native plants as important feeding areas.

SUPPORTING INFORMATION CHAPTER V

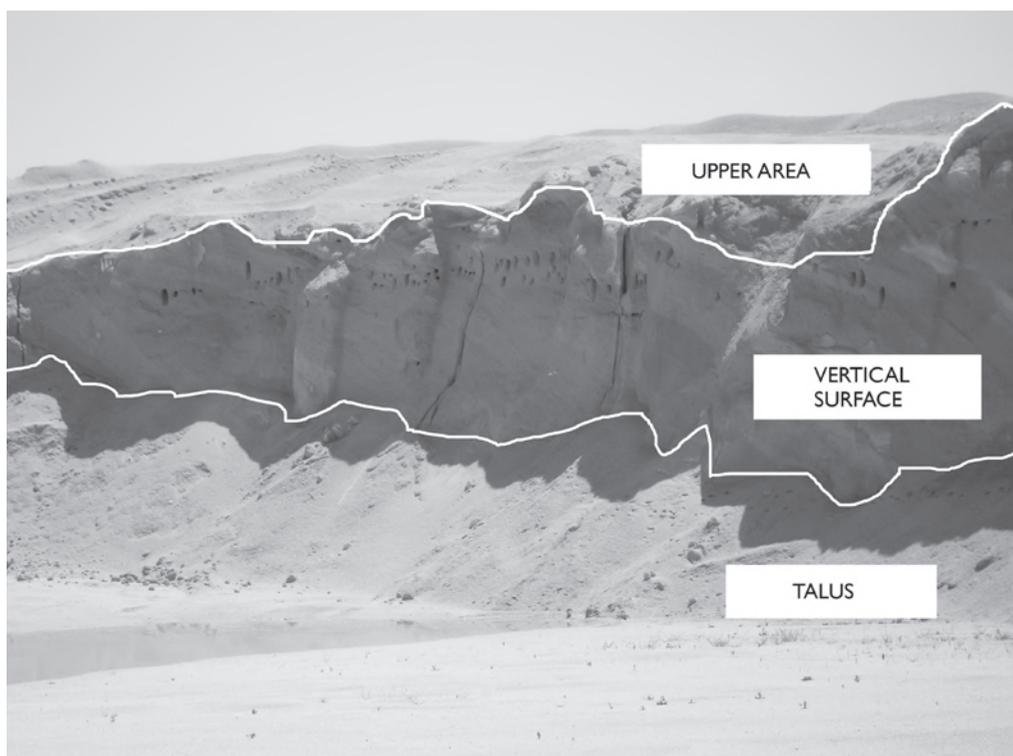

Fig. S5.1 Upper area, vertical surface and talus of a stockpile. The vertical surface was used to calculate burrow density.

Table S5.1 Maximum burrow density in 1 m² estimated in the six densest colonies. The colonies are ordered by decreasing density.

Colony	Maximum burrow density (burrows/ m ²)
COR1	34
ROM7	26
ESP1	23
EMO1	22
LPO1	20
MAT21	20

Table S5.2 Variables related to the structure of the colonies in 2017: Length, maximum and minimum height of the structure, existence or not of mining activity, type of structure where the colony was located, and type of material of the structure. The colonies are ordered from greater to shorter length.

Mining site	Colony	Length (m)	Maximum height (m)	Minimum height (m)	Mining activity	Type of structure	Material
EPU	EPU1	248.6	10.7	7.7	inactive	vertical extraction face	topsoil
EPU	EPU2	248.6	–	–	inactive	vertical extraction face	topsoil
ROM	ROM7	244.3	5.6	1.8	inactive	vertical extraction face	sand
EPU	EPU3	164	6.4	5.1	inactive	vertical extraction face	sand and gravel
EMO	EMO1	147.3	11	1.5	inactive	stockpile	sand
LCH	LCH1	139.8	6.9	0	inactive	stockpile	sand
COR	COR4	133.1	17.8	8.9	inactive	vertical extraction face	sand and silt
ROM	ROM5	128.8	3.1	1	inactive	vertical extraction face	sand
ROM	ROM3	121.1	4.8	0	inactive	vertical extraction face	sand
PRE	PRE1	111	6.8	3.1	inactive	vertical extraction face	sand
COR	COR5	110	13.2	11.4	inactive	vertical extraction face	sand and gravel
ROM	ROM8	107.2	4.5	0	inactive	vertical extraction face	sand
COR	COR1	104.6	5.8	0	inactive	stockpile	sand
CTO	CTO1	103.8	13.3	8.6	inactive	vertical extraction face	clay
ESP	ESP1	101.2	4.6	1.6	inactive	stockpile	sand
LPO	LPO1	96.5	17.6	0	inactive	vertical extraction face	mixture of materials
ESP	ESP3	91.5	1.88	0.9	inactive	stockpile	sand
COR	COR3	88.1	14	14	inactive	vertical extraction face	sand and silt
ROM	ROM2	83	2	0	inactive	vertical extraction face	sand
ROM	ROM1	66.2	4.1	2.1	inactive	vertical extraction face	sand
MAT	MAT2	63.4	3.7	0	inactive	stockpile	sand
LCH	LCH2	57.5	15.2	0	inactive	stockpile	sand
COR	COR2	51	4.3	0.6	inactive	stockpile	sand
LCH	LCH3	46.7	8.6	6.1	inactive	stockpile	sand
COR	COR6	42.8	13.9	12.7	inactive	vertical extraction face	sand and gravel
MAT	MAT3	28.3	8.3	0	active	stockpile	sand
MAT	MAT1	26.5	5.3	0	inactive	stockpile	sand
ESP	ESP2	25.8	10.9	9.4	inactive	vertical extraction face	sand
ROM	ROM6	22.6	2.6	2	inactive	vertical extraction face	sand
LPO	LPO2	16.4	6.3	5.4	active	stockpile	sand

Table S5.3 Number of burrows, total secondary user pairs, secondary user species richness, and pairs and occupation rate (Occup. rate) for Sand Martin, Black Redstart, Rock Sparrow, Eurasian Tree Sparrow and Little Owl. Colonies are ordered in descending number of burrows.

Colony	Burrows	Total Secondary user pairs	Secondary user richness	Sand Martin		Black Redstart		Rock Sparrow		House Sparrow		Eurasian Tree Sparrow		Little Owl	
				Pairs	Occup. rate	Pairs	Occup. rate	Pairs	Occup. rate	Pairs	Occup. rate	Pairs	Occup. rate	Pairs	Occup. rate
ROM7	1324	1	1	0	0	0	0	0	0	0	0	1	0.1	0	0
PRE1	1155	0	0	0	0	0	0	0	0	0	0	0	0	0	0
EMO1	1070	47	2	40	3.7	1	0.1	46	4.3	0	0	0	0	0	0
LPO1	811	29	2	91	11.2	0	0	27	3.3	0	0	0	0	2	0.2
ROM1	578	1	1	24	4.2	0	0	0	0	0	0	1	0.2	0	0
ROM5	510	0	0	0	0	0	0	0	0	0	0	0	0	0	0
CORI	409	5	2	63	15.4	0	0	4	1	1	0.2	0	0	0	0
COR3	328	3	1	38	11.6	0	0	0	0	3	0.9	0	0	0	0
ESP1	316	8	2	124	39.2	0	0	7	2.2	1	0.3	0	0	0	0
EPUI	293	0	0	0	0	0	0	0	0	0	0	0	0	0	0
COR4	243	0	0	2	0.8	0	0	0	0	0	0	0	0	0	0
COR6	240	4	2	0	0	0	0	3	1.3	0	0	1	0.4	0	0
MAT1	237	3	1	129	54.4	0	0	3	1.3	0	0	0	0	0	0
EPUI	227	0	0	0	0	0	0	0	0	0	0	0	0	0	0
MAT2	168	1	1	70	41.7	0	0	1	0.6	0	0	0	0	0	0
ROM8	143	0	0	0	0	0	0	0	0	0	0	0	0	0	0
MAT3	117	0	0	50	42.7	0	0	0	0	0	0	0	0	0	0
LPO2	105	1	1	34	32.4	0	0	1	1	0	0	0	0	0	0
LCHI	84	0	0	4	4.8	0	0	0	0	0	0	0	0	0	0
ROM2	84	0	0	1	1.2	0	0	0	0	0	0	0	0	0	0
ROM3	83	0	0	0	0	0	0	0	0	0	0	0	0	0	0
LCH2	67	3	1	1	1.5	0	0	3	4.5	0	0	0	0	0	0
EPUI	50	0	0	0	0	0	0	0	0	0	0	0	0	0	0
ESP2	43	1	1	0	0	0	0	1	2.3	0	0	0	0	0	0
COR2	40	1	1	5	12.5	0	0	1	2.5	0	0	0	0	0	0
COR5	40	0	0	0	0	0	0	0	0	0	0	0	0	0	0
CTO1	38	0	0	4	10.5	0	0	0	0	0	0	0	0	0	0
ROM6	30	0	0	0	0	0	0	0	0	0	0	0	0	0	0
LCH3	10	0	0	0	0	0	0	0	0	0	0	0	0	0	0
ESP3	6	0	0	0	0	0	0	0	0	0	0	0	0	0	0
Total	8849	108	5	680		1		97		5		3		2	

Table S5.4 Relationship between predictor variables. We used Spearman's correlations or the Mann-Whitney U test depending on the nature of the variables. We eliminated correlated variables from the GLMM models. Predictor variables are ordered alphabetically in column one.

Predictor variable 1	Predictor variable 2	Relationship
Number of burrows	Age of the structure	$S = 4832.7, p = 0.693, r = -0.08$
Sand Martin abundance	Number of burrows	$S = 3094.1, p = 0.094, r = 0.31$
Sand Martin abundance	Age of the structure	$S = 6015.4, p = 0.068, r = -0.34$
Type of structure	Sand Martin abundance	$W = 174, p = 0.003$
Type of structure	Number of burrows	$W = 86, p = 0.363$
Type of structure	Age of the structure	$W = 58.5, p = 0.037$

Table S5.5 Highest-ranked Poisson models using AICc-based model selection for secondary cavity-nesting species abundance at colony scale. The model includes three standardized continuous variables (Sand Martin abundance, age of structure and number of burrows). Models are ranked in increasing value of AICc.

Intercept	Sand Martin abundance	Age of structure	No. of burrows	df	logLik	AICc	delta	weight
-0.344	0.812		0.856	4	-46.83	103.26	0	0.77
-0.343	0.765	-0.112	0.877	5	-46.70	105.90	2.64	0.21
-0.321	1.202			3	-52.25	111.42	8.17	0.01
-0.631		-0.410	1.445	4	-51.98	113.57	10.31	0.00
-0.739			1.508	3	-53.55	114.03	10.78	0.00
-0.321	1.206	0.012		4	-52.25	114.10	10.84	0.00
0.127		-0.394		3	-76.62	160.16	56.90	0.00
0.139				2	-78.15	160.74	57.49	0.00

Table S5.6 Highest-ranked Poisson models using AICc-based model selection for secondary cavity-nesting species richness at colony scale. The model includes three standardized continuous variables (Sand Martin abundance, age of structure and number of burrows). Models are ranked in increasing value of AICc.

Intercept	Sand Martin abundance	Age of structure	No. of burrows	df	logLik	AICc	delta	weight
-0.617	0.506			3	-27.39	61.71	0	0.35
-0.699	0.498		0.354	4	-26.09	61.78	0.07	0.34
-0.618	0.515	0.024		4	-27.39	64.38	2.67	0.09
-0.7	0.494	-0.011	0.355	5	-26.09	64.68	2.97	0.08
-0.606			0.402	3	-29.34	65.61	3.9	0.05
-0.685		-0.366	0.445	4	-28.44	66.49	4.78	0.03
-0.483				2	-31.09	66.63	4.93	0.03
-0.541		-0.306		3	-30.4	67.72	6.01	0.02

Table S5.7 Highest-ranked Binomial models using AICc-based model selection for secondary cavity-nesting species occupation at colony scale. The model includes three standardized continuous variables (Sand Martin abundance, age of structure and number of burrows). Models are ranked in increasing value of AICc.

Intercept	Sand Martin abundance	Age of structure	No. of burrows	df	logLik	AICc	delta	weight
-5.418	0.514			3	-46.44	99.81	0	0.44
-5.407	0.454	-0.148		4	-46.21	102.02	2.22	0.15
-5.43	0.507		0.024	4	-46.44	102.48	2.67	0.12
-5.237				2	-49.32	103.07	3.27	0.09
-5.247		-0.319		3	-48.23	103.38	3.58	0.07
-5.487			0.309	3	-48.54	104	4.2	0.05
-5.484		-0.321	0.305	4	-47.46	104.51	4.71	0.04
-5.436	0.431	-0.157	0.058	5	-46.19	104.88	5.07	0.04

Table S5.8 Highest-ranked Poisson models using AICc-based model selection for Rock Sparrow abundance at colony scale. The model includes three standardized continuous variables (Sand Martin abundance, age of structure and number of burrows). Models are ranked in increasing value of AICc.

Intercept	Sand Martin abundance	Age of structure	No. of burrows	df	logLik	AICc	delta	weight
-0.460	0.527	-0.625	1.029	5	-57.595	127.690	0.00	0.698
-1.020		-0.817	1.665	4	-60.321	130.243	2.55	0.195
-0.380	0.717		0.907	4	-61.022	131.644	3.96	0.097
-0.402	1.144	-0.476		4	-63.768	137.14	9.45	0.006
-0.340	1.233			3	-65.889	138.701	11.01	0.003
-1.437			1.894	3	-66.148	139.220	11.53	0.002
-0.119		-0.997		3	-99.787	206.498	78.81	0.000
-0.027				2	-108.738	221.921	94.23	0.000

Table S5.9 Highest-ranked Binomial models using AICc-based model selection for Rock Sparrow occupation at colony scale. The model includes three standardized continuous variables (Sand Martin abundance, age of structure and number of burrows). Models are ranked in increasing value of AICc.

Intercept	Sand Martin abundance	Age of structure	No. of burrows	df	logLik	AICc	delta	weight
-5.796		-0.845		3	-42.823	92.570	0.000	0.400
-5.871	0.303	-0.681		4	-42.101	93.802	1.233	0.216
-5.969		-0.829	0.255	4	-42.434	94.468	1.898	0.155
-5.811	0.503			3	-44.265	95.453	2.883	0.095
-5.894	0.275	-0.692	0.054	5	-42.091	96.681	4.111	0.051
-5.695				2	-46.407	97.258	4.688	0.038
-5.779	0.534		-0.074	4	-44.242	98.084	5.514	0.025
-5.969			0.324	3	-45.816	98.556	5.986	0.020

PHOTOGRAPHIC APPENDIX



Figures 1 – 4 Panoramic views of different quarries and gravel pits.



Figures 5 – 8 Examples of different extraction faces, from quarries and gravel pits.



Figures 9 – 12 Examples of different stock piles of different materials and ages.



Figures 13 – 16 Images of Eagle Owl nests



Figure 17 European Bee-eater (*Merops apiaster*) nest



Figure 18 Sand Martin (*Riparia riparia*) nests

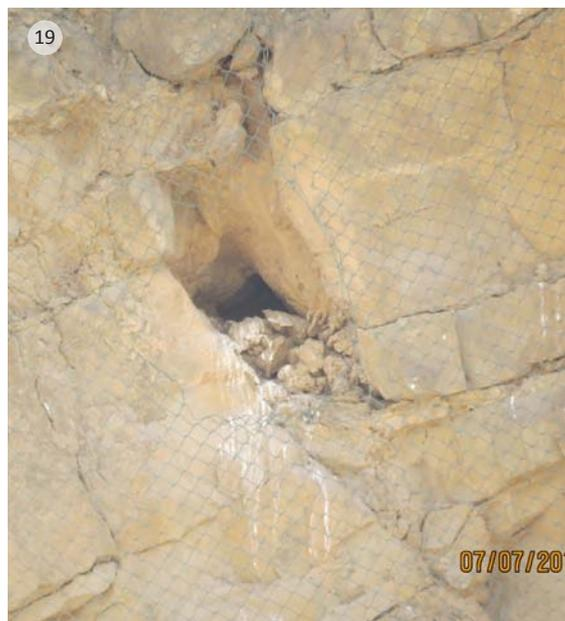

19



20

Figures 19 – 20 Common Kestrel (*Falco tinnunculus*) nests



Figure 21 Northern Wheatear (*Oenanthe oenanthe*) nests



Figure 22 Black Wheatear (*Oenanthe leucura*) nest



Figures 23 – 24 Spotless Starling (*Sturnus unicolor*) nests



Figures 25 – 26 Rock Sparrow (*Petronia petronia*) nests



Figures 27 – 29 Common House Sparrow (*Passer domesticus*) nests



Figures 30 – 36 Western Jackdaw (*Corvus monedula*) nests



Figure 37 European Bee-eater (*Merops apiaster*)



Figure 38 Crag martin (*Ptyonoprogne rupestris*)



Figure 39 Sand Martin chicks (*Riparia riparia*)



Figure 40 Sand Martin adults (*Riparia riparia*)



Figure 41 – 43 Eagle Owl (*Bubo bubo*)



Figure 44 Common Kestrel fledgling (*Falco tinnunculus*)



Figure 45 Red-billed Chough (*Pyrrhocorax pyrrhocorax*)



Figure 46 Northern Wheatear (*Oenanthe oenanthe*)



Figure 47 Black Wheatear (*Oenanthe leucura*)



Figure 48 Black-eared Wheatear adult (*Oenanthe hispanica*)



Figure 49 Black-eared Wheatear fledgling (*Oenanthe hispanica*)



Figure 50 Rock Sparrow (*Petronia petronia*)



Figure 51 Western Jackdaw (*Corvus monedula*)



Figure 52 Peregrine falcon (*Falco peregrinus*)



Figure 53 Little Owl (*Athene noctua*)



Figure 54 Rock dove (*Columba livia*)



Figure 55 Banding a Sand Martin



Figure 56 Surveys of Sand Martin colony



Figure 57 Measuring Sand Martin colonies



Figure 58 Detail of Sand Martins trapped in self-supporting hoops with mist nets



Figure 59 Collecting Eagle Owl pellets



Figure 60 Surveying a mining site



*'Hope' is the thing with feathers –
That perches in the soul –
And sings the tune without the words –
And never stops – at all –*

Emily Dickinson

